



Pond Pump system-X

X-Designed Magnetic Rotor Technology

High-performance pump for small brooks, filter systems
and fountains.

Fields of Application

- ✓ Waterfalls
- ✓ Brooks
- ✓ Filter Operations
- ✓ Water Circulations
- ✓ Fountain Displays
- ✓ Fountains



Pond Pump system-X

Ergonomic handle



Filter housing with large suction-surfaces for long maintenance intervals



No tools required for opening



Optimal for use with small fountains

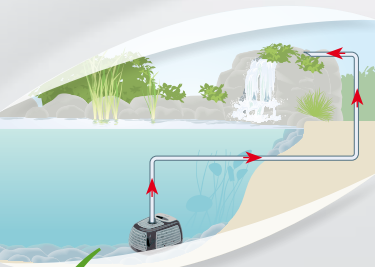

Optimal for small waterfalls



Inclusive extensive accessories



10 m cable H05

Removable rotor assembly

Removable pre-filter cap, no tools required

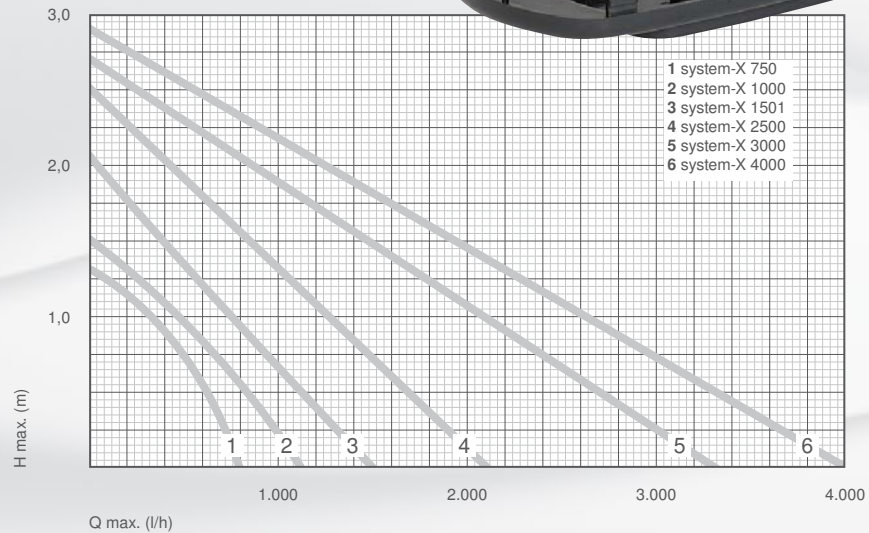



	system-X 750	system-X 1000	system-X 1501	system-X 2500	system-X 3000	system-X 4000
	13 l/min 800 l/h	18 l/min 1.100 l/h	25 l/min 1.500 l/h	35 l/min 2.100 l/h	55 l/min 3.300 l/h	67 l/min 4.000 l/h
	1,30 m	1,50 m	2,10 m	2,50 m	2,70 m	2,90 m
	15 W	18 W	30 W	45 W	45 W	60 W
	230 V / 50 Hz	230 V / 50 Hz	230 V / 50 Hz	230 V / 50 Hz	230 V / 50 Hz	230 V / 50 Hz
	165 x 140 x 105	165 x 140 x 105	165 x 140 x 105	165 x 140 x 105	205 x 165 x 130	205 x 165 x 130
	G 1/2" - I	G 1/2" - I	G 1/2" - E	G 1/2" - E	G 3/4" - E	G 3/4" - E
			Ø 25 mm	Ø 25 mm	Ø 32 mm	Ø 32 mm
Art.-No.	156 / 001375	156 / 001376	156 / 001377	156 / 001372	156 / 001379	156 / 001380



* not including rotor unit (part subject to wear)



Scope of delivery

system-X 750
system-X 1000



system-X 1501
system-X 2500



system-X 3000
system-X 4000

