



ADVANCED REVERSE OSMOSIS SYSTEM

USER MANUAL

**REVERSE OSMOSIS
SYSTEMS**

ADVANCED REVERSE OSMOSIS SYSTEM

INDEX

P

1	User manual	4
2	Technical manual	8
3	Sanitization procedure	14
4	Data sheet	19

USER MANUAL

REVERSE OSMOSIS SYSTEM

0. MAIN SPECIFICATIONS



CLICK

QUICK CONNECTIONS
MAXIMUM SECURITY



FILTER CONTROL

AUTOMATIC
MAINTENANCE WARNING



SOLENOID VALVE

IMMEDIATE CONTROL
SAFETY MESH



AQUASTOP

AUTOMATIC LEAK
DETECTION SYSTEM



DIRECT FLOW

RO WATER
DIRECT PRODUCTION



LED STATUS

LIGHT
INDICATIONS



HIGH PERFORMANCE MOTOR

BETTER
PERFORMANCE



SMART FAUCET

FILTER CHANGE
WARNINGS

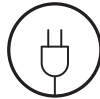

ELECTRONIC ADAPTER

GREATER SECURITY
AND EFFICIENCY



DOUBLE FLOW

HIGHER FLOW
OF WATER DISPENSED



DIRECT ACCESS

EASY ACCESS
AND MAINTENANCE



QUALITY CONTROL

CONDUCTIVITY
CONTROL



SOUND WARNINGS

SOUND
INDICATIONS



PRESSURE CONTROL

PROTECTION AGAINST
PRESSURE DROPS



HIGH EFFICIENCY

RECOVERY
IN PRODUCTION

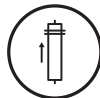

EXCLUSIVE MEMBRANE

ORIGINAL
MEMBRANE



Please keep this manual which includes the service and warranty book sections in order to provide you with a better after-sales service.

1. INTRODUCTION

Congratulations. You have acquired an excellent household water treatment equipment.

This equipment will help you improve the characteristics of water.

2. ¿WHAT IS OSMOSIS?

Natural or direct osmosis is the most common in nature, since semi-permeable membrane is part of the vast majority of organisms (for example plant roots, organs of our body, cell membranes, etc...).

When two solutions of different salt concentrations are separated by a semi-permeable membrane, in a natural way, there is a flow of water from the lower concentration solution to the higher concentration one. This flow continues until the concentration of both sides of the membrane equalize.

When it comes to reversing this process and achieving a flow of water with a lower concentration of salts from one with a higher concentration, sufficient pressure must be applied to the water with higher concentration on the membrane to overcome the tendency and natural flow of the system. This process is what we call reverse osmosis. At present, reverse osmosis is one of the best methods to improve the specifications of water, through a physical system (without the use of chemical products).

The water to be purified exerts pressure on the semi-permeable membrane, so that part of it will pass through the pores of the membrane (RO Water) while the rest of the water (rejected or with a high concentration of salts) will be diverted towards the drain (Fig. 1).

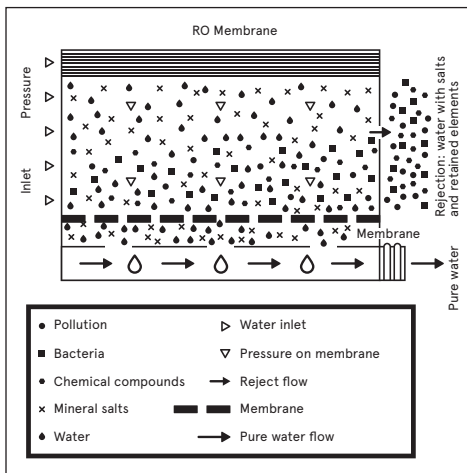

3. PRIOR WARNINGS

! ATTENTION: read carefully the warnings described in the corresponding section of the Technical Manual.

! ATTENTION: these equipments ARE NOT POTABILIZING water. If the water to be treated comes from a public supply (and therefore complies with current legislation), this equipment with substantially improve the quality of the water.

Water treatment equipments requires periodic maintenance carried out by qualified technicians in order to guarantee the quality of the water produced and supplied.

3.1. USE OF THE EQUIPMENT

· When you are going to be absent for more than a week, close the water inlet tap to the equipment, drain it and disconnect it from the power supply (PUMP model). When you return, connect the electrical supply to it, open the inlet valve and the tap. Let the water run out for at least 5 minutes before consuming the water.

! ATTENTION: After a prolonged period (more than a month) in which the equipment has been without working or producing water, contact your distributor in order to carry out adequate sanitation and maintenance.

· Remove entire jugs or bottles and avoid occasional removal of glasses to improve equipment performance.

! ATTENTION: Special attention must be paid to the cleaning and hygiene of the osmosis tap, in the usual way and especially at the time of periodic maintenance and sanitization. To do this, use the sanitizing spray and single-use disposable kitchen paper. In no case should you use the cloth to dry your hands or the multipurpose basket used for cleaning the kitchen.

This appliance can be used by children aged 8 years and above and persons with reduced physical, sensory or mental capabilities or lack of experience and knowledge if they have been given supervision or instruction concerning use of the appliance in a safe way and understand the hazards involved. Children shall not play with the appliance. Cleaning and user maintenance shall not be made by children without supervision.

3.2. RECOMMENDATIONS FOR THE CORRECT USE OF OSMOTIZED WATER

· If you want to feed osmotic water to any other point of consumption (such as a refrigerator with an ice cube dispenser, another tap, etc ...), the canalization should not be done with a metal tube, as this would give the water a bad taste. Always use plastic tubing.

! ATTENTION: The water provided by the domestic osmosis equipment is LOW MINERALIZATION. The mineral salts that the human body needs are provided mainly by food, especially dairy products and to a lesser extent by drinking water.

- It is recommended not to use aluminum utensils to cook with osmotic water.

4. BASIC OPERATION

The mains water to be treated enters the equipment through the sediment and carbon filter. In this filtration stage, the suspended particles, chlorine, its derivatives and other organic substances are retained.

The passage of water into the equipment is controlled by a cut-off solenoid valve.

The water, after being treated in the filtration stage, is driven towards the reverse osmosis membranes. The equipment incorporates a pump to increase the pressure, since the pressure of the water on the membrane makes the reverse osmosis process possible.

The osmotized water comes out of the equipment through the tap for consumption. Reject water or water with excess salts and other dissolved substances is directed to the drain for disposal.

When you stop requesting water through the tap, the equipment stops operating by means of a maximum pressure switch.

This equipment incorporates a minimum pressure switch as a safety system, which protects the pump from pressure drops, stopping the equipment and preventing its operation in vacuum.

5. USER INTERFACE

! ***ATTENTION: This equipment incorporates an electronic controller that will efficiently manage the functionality and status indications in which it is located, as well as the different security systems.***

The technical data sheet of the equipment describes the states in which the system can be found and the information provided by it (pages 20-22 of this manual).

6. MAINTENANCE

In order to guarantee the quality of the water supplied by your equipment, regular maintenance must be carried out.

Read the corresponding section of the Technical Manual to see the recommended maintenance frequency (page 11 of this manual).

7. IDENTIFICATION AND RESOLUTION OF PROBLEMS

PROBLEM	POSSIBLE CAUSE	SOLUTION
1. Leak outside the equipment.	Many possible causes.	Call technical service.
2. Zero production.	<ol style="list-style-type: none"> 1. There is no water supply. 2. There is no power supply. 3. Leak sensor activated. 	<ol style="list-style-type: none"> 1. Wait for the supply to return. 2. Check the electrical supply to the house. If the problem is not solved, call the technical service. 3. Leak sensor activated. If the leak is not detected, dry the bottom of the equipment together with the leak sensor. If it happens again, call the technical service.
3. Low production.	<ol style="list-style-type: none"> 1. Fuel tap partially closed. 2. Filters / membrane in poor condition or exhausted. 	<ol style="list-style-type: none"> 1. Open it completely. 2. Call technical service.
4. Excessive production.	Several possible causes.	Call technical service.
5. Unpleasant taste and smell.	Several possible causes.	Call technical service.
6. White water color.	Air in the system. Microbubbles of air that disappear after a few seconds.	This is not a problem. The appearance will disappear as the air is eliminated inside the equipment.
7. Continuous dripping noise in drain.	Several possible causes.	Call technical service.
8. The equipment does not start.	<ol style="list-style-type: none"> 1. There is no water supply. 2. There is no power supply. 3. Leak sensor activated. 	<ol style="list-style-type: none"> 1. Check the condition of the general key and the equipment input. 2. Check the general power supply. If the problem is not solved, call the technical service. 3. If the leak is not detected, wipe the bottom of the equipment together with the leak sensor. If it repeats, call for service.
9. The equipment starts and stops constantly.	Several possible causes.	Call technical service.
10. The equipment never stops rejecting water down the drain.	<ol style="list-style-type: none"> 1. Inlet solenoid valve damaged. 2. Deteriorated production anti-return. 	<ol style="list-style-type: none"> 1. Check and replace. 2. Check and replace.

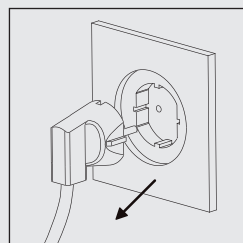
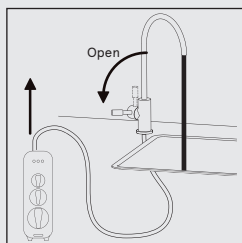
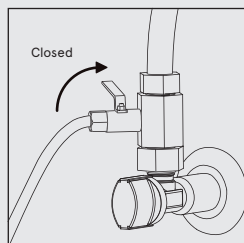

Read the INTERFACE section of the Data sheet. In case of anomaly, contact the SAT and proceed as indicated: Close the inlet valve. Open the tap to depressurize the system and disconnect the plug.

TECHNICAL MANUAL

REVERSE OSMOSIS SYSTEMS

1. MAIN SPECIFICATIONS

APPLICATION

Water treatment
Reverse osmosis

Use
Improvement of the drinking water specifications (that complies with the requirements of the European Directive on water for human consumption 98/93 or its national transpositions in the different member states of the European Community).

Modifications for reduction or contribution

· Water treatment by reverse osmosis is capable of reducing concentration of salts and other substances in high percentages.

· Minimal reduction* of certain compounds and parameters:

Sodium: 90%.
Calcium: 90%.
Sulfate: 90%.
Chloride: 90%.
Total hardness: 90%.
Conductivity: 90%.

* Depending of the characteristics of water to be treated (at the membrane outlet). These values may vary depending on the type of post-filter that the equipment incorporates and / or regulation of the mixing valve (if it is included).

WORKING LIMITS

	PUMP SYSTEM
Pressure (max./min.):	4 bar - 1 bar (400kPa-100kPa) .
TDS (max.):	1500ppm.
Temperature (max./min.):	38 °C - 5 °C.
Hardness (max.):	15 °HF. **

! **ATTENTION:** *If you have any questions about the installation, use or maintenance of this equipment, contact the technical assistance service (SAT) of your distributor.*

2. PRIOR WARNINGS

! **ATTENTION:** *the equipment IS NOT POTABILIZING water. In the event that the water to be treated comes from a public supply (and therefore complies with current legislation), this equipment will substantially improve the quality of the water.*

! **ATTENTION:** *If the water to be treated does not come from a public supply network or is of unknown origin, it will be necessary to carry out a physical-chemical and bacteriological analysis of the water to ensure its correct purification by applying the techniques and adequate equipment for each need, PRIOR TO THE INSTALLATION of the equipment. Contact your dealer with object to advise you on the most*

appropriate treatment for your case.

2.1. CONDITIONS FOR THE CORRECT OPERATION OF THE EQUIPMENT

- The equipment should not be fed with hot water (T> 38°C).
- The ambient temperature must be between 4° and 45°C.
- For waters with salinities higher than 1500 ppm, consult your distributor.

- It is recommended that the water to be treated be de-calcified or with a maximum hardness of 15°HF in order to obtain optimum performance from the equipment.

- In the event that the water to be treated is of a hardness greater than 15°HF, it could cause a reduction in the life of the membrane and in the performance of the equipment.

- If the make-up water contains a concentration higher than 1.2 ppm of total chlorine, the installation of an activated carbon dechlorinator filter is recommended to reduce the chlorine concentration in the water and thus protect and extend the life of the equipment components.

In case the water to be treated contains:

High concentrations of iron and manganese (Greater than 1ppm measured in the rejection of the machine).

Prolonged hyperchlorination in time. Sludge or turbidity greater than 3 NTUs.

A nitrate concentration greater than 100 ppm. A sulfate concentration greater than 250 ppm.

- Contact your distributor to recommend the most appropriate pretreatment for your case, thus ensuring the correct operation of the equipment, avoiding damage to components and guaranteeing the quality of the water supplied.

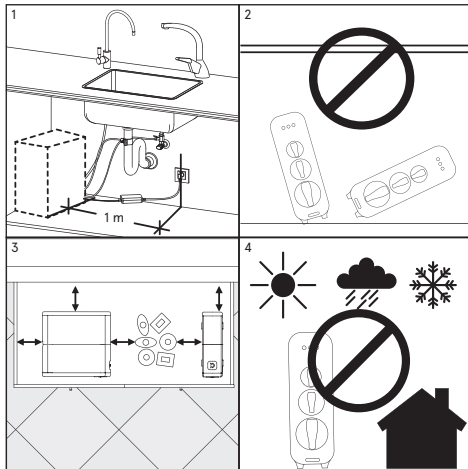

3. INSTALLATION

- In the event that the home installation has to be conditioned in order to install the equipment in the planned place, it must be carried out in accordance with the national regulations for indoor installations of water and electrical supplies.

- These equipments need an electrical outlet less than 1 meter away (1).

- These equipments must not be installed either lying down or inclined (2), as the leak sensor would be disabled.

The equipment filled with water weighs more, the distribution of weights in an unexpected position could cause some connection element to be forced, which could cause a malfunction, damage to equipment components or loss of water.

- The place planned for its installation must have sufficient space for the appliance itself, its accessories, connections and for carrying out convenient maintenance (3).

- Under no circumstances will the equipment be installed outdoors (4).

- The environment and environment where equipment and faucet are installed must keep adequate hygienic-sanitary conditions.

- The appliance is only to be used with the power supply unit provided with the appliance.

- This appliance must only be supplied at safety extra low voltage.

- Avoid external drips on the equipment, coming from pipes, drains, etc.

! **ATTENTION:** *The equipment must not be installed next to a heat source or directly receiving a flow of hot air over it (dryer, refrigerator, etc.). The new hose-sets supplied with the appliance are to be used and that old hose-sets should not be reused.*

3.1. COMMISSIONING AND MAINTENANCE

! **ATTENTION:** *The water treatment equipment requires periodic maintenance carried out by qualified technical personnel, in order to guarantee the quality of the water produced and supplied.*

- The new hose-sets supplied with the appliance are to be used and that old hose-sets should not be reused.

- The consumable elements must be replaced with the frequency indicated by the manufacturer.

- The equipment must be sanitized periodically and prior to commissioning.

- After commissioning, you must discard the water produced during the first 30 minutes of use.

- Maintenance must be carried out by qualified technical personnel, with adequate hygienic conditions and attitudes, in order to reduce the risk of internal contamination of the appliance and its hydraulic system. (For more information contact the technical service of your distributor).

4. UNPACKING

It is important that before installation and start-up, you check the box and the condition of the equipment, in order to guarantee that it has not been damaged during transport.

! ATTENTION: Claims for damage during transport must be submitted together with the delivery note or invoice to your distributor, attaching the name of the carrier within a maximum period of 24 hours after receipt of the merchandise.

Remove the equipment and accessories from their carton, removing the corresponding protections.

! ATTENTION: Dispose of properly and keep plastic bags out of reach of children, as they can be a danger to them.

Inside you will find: Water treatment equipment, installation accessories and documentation. The materials used in the packaging are recyclable and must be disposed of in the appropriate separate collection containers or in the



specific local center for the recovery of waste materials. This product cannot be disposed of together with normal municipal waste. When the useful life of the equipment has ended, it must be delivered to the company or center where the device was purchased, or to a

Clean Point or specific local center for the recovery of materials, indicating that it has electrical and electronic components. The correct collection and treatment of useless appliances contributes to preserving natural resources and also to avoiding potential risks to public health.

5. INSTALLATION

The installation of your osmosis equipment must be carried out by personnel sufficiently qualified to do so. Read this manual first and consult your dealer in case of doubt.

! ATTENTION: Since the appliance to be installed improves the quality of the water to be consumed, all the tools to be used for assembly and installation must be clean and in no case may they be contaminated or impregnated with fats, oils or oxides. Use dedicated tools for tube cutting, membrane handling, etc. Keep them clean and disinfect them periodically.

! ATTENTION: The work must be carried out with a suitable hygienic attitude and conditions, taking extreme precautions in everything related to materials and components that are going to be in contact with the water to be treated or consumed.

(For more information contact your dealer).

! ATTENTION: Avoid the risks of external contamination of the equipment due to improper handling, using gloves, hand sanitizing gel or washing hands as many times as necessary throughout the installation, start-up and maintenance of the equipment.

The most common place to install the equipment is usually under the kitchen sink or in an attached cabinet. Install the tap, hydraulically and electrically, to the equipment drain collar and inlet socket adapter and connect them to the respective connectors on the equipment (5, 6, 6.1 and 7). Note that for the cable to pass through, the hole must be at least 16mm.

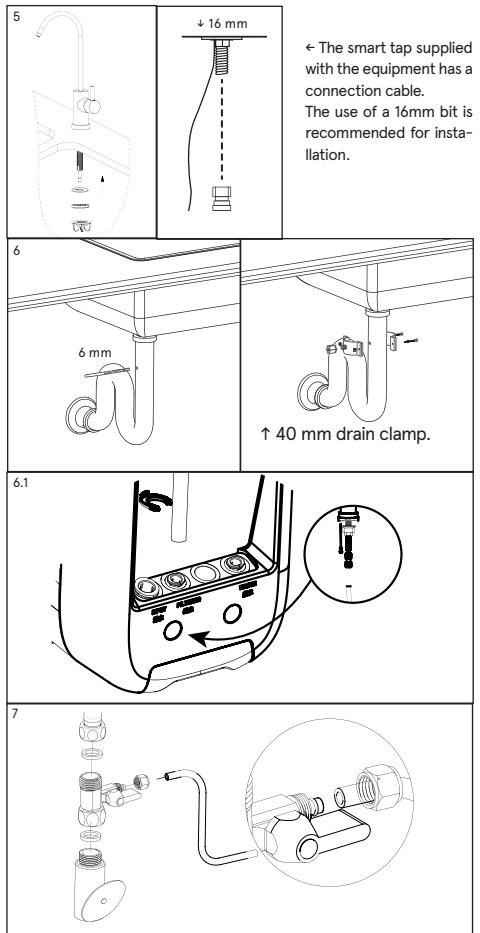

← The smart tap supplied with the equipment has a connection cable. The use of a 16mm bit is recommended for installation.

Hydraulic diagram on page 13.

! ATTENTION: Some of the installation accessories may vary depending on the model and the region in which the equipment is distributed.

5.1. MIXING KIT

· In case you want to increase the pH, conductivity and chlorine concentration at the outlet, you must carry out the installation according to the following scheme and using the corresponding components included in the mixing kit (consult your distributor).

· After start-up, open the tap and with the corresponding meter for the parameter of interest, measure in the water dispensed from the tap and slowly and progressively open the mixing valve until the desired parameter is achieved.

· The water dispensed must comply with the drinkability requirements established by European Directive 98/83 or the corresponding national legislation that transposes it.

5.2. INSTALLATION OF THE FILTERS

- Remove the rubber plugs from the water inlets of the pre-filter (CF), the membrane (RO) and the post-filter (CB) as shown in figures 8, 9 and 10.

- Install the CF filter in the first stage of the equipment (lower position), the RO membrane in the second stage of the equipment (upper position) and the post-filter CB in the third stage of the equipment (middle position).

- To install the filters, present each filter in its respective housing with the handle in a horizontal position, as shown in figure 11.

- Insert firmly all the way and turn the handle 90 degrees clockwise. After installation, the three filters should be as shown in figure 12.

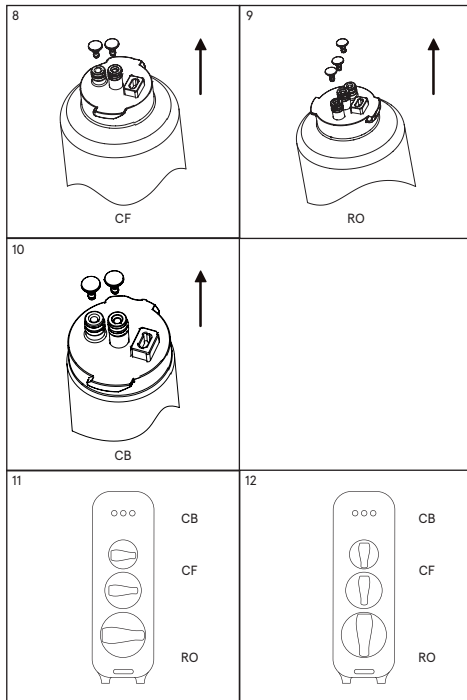

6. START-UP

6.1. FILTER RINSING

- It is necessary to eliminate the dust that the filter granular carbon that is generated during the transport and handling of the equipment and corresponding. This dust must be eliminated since it could partially or completely obstruct the membrane as well as cause a malfunction of the equipment. The equipment will automatically perform a wash when replacing the filters.

6.2. SANITIZATION OF THE SYSTEM

- Carry out a sanitization of the equipment, depending

on the model and procedure indicated by the manufacturer (see Hygienization procedure). If in doubt, consult your dealer.

6.3. SYSTEM TIGHTNESS, STOP AND START

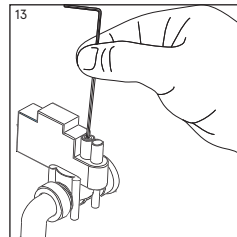

- Close the tap of the equipment on the hob and keep the water powered hydraulically or electrically the equipment conducting an eye check of the system to ensure that there is no leak (for approx.).

- In case the pump the equipment does not stop, adjust the tare of the maximum pressure switch with an Allen key size 2, until the pump (13) is stopped. Open the dispensing tap. The equipment should wake up and supply water. Close the tap again and check that the equipment stops.

6.4. RINSE AND CLEAN

- Open the tap of the equipment and measure the quality of the water that is being produced. With a conductivity or TDS meter, check that the reduction of salts obtained is adequate with respect to the water to be treated (14).

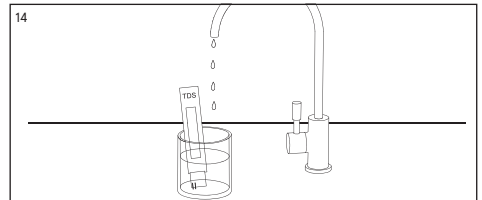

! ATTENTION: *in case of detecting that the dispensed water does not comply with the current national legislation, carry out the measurement again. If the deviation persists, close the equipment inlet valve, drain it through the tap, disconnect it electrically and contact your technical service.*

- Finally, clean the inside and the bottom of the equipment with single-use blotting paper, in order to remove any water that may have fallen into it, as it could cause a false alarm and system blockage.

7. MAINTENANCE

! ATTENTION: *Some components of your equipment, such as the pre-filters and the membrane, are consumables that have a limited life.*

The duration will depend on the quality of the local water, consumption, type of use and specific aspects of the water to be treated such as extreme turbidity, high chlorination, excess iron, etc.

! ATTENTION: *In order to guarantee the quality of the water supplied by your equipment, periodic maintenance must be carried out.*

RECOMMENDED MAINTENANCE

CF Prefilter: 12 months or 11,000 liters
RO osmosis membrane: 60 months or 20,000 l. for soft waters to be treated. (hardness <15 °HF).
CB Postfilter: At least every 12 months or 4000 liters.
Sanitization: At start-up. At least every 12 months depending on use. Every time components in contact with water in the equipment are accessed or no water has been consumed for more than a month.

** Depending on the intended use and characteristics of the water to be treated.*

Maintenance must be carried out by trained personnel, who must handle the equipment properly, as well as use original spare parts to maintain the characteristics, guarantee, certifications and performance of the equipment and thus preserve the quality of the water dispensed.

! **ATTENTION:** *The use of non-original spare parts, installation outside the operating limits and improper commissioning, maintenance or use, may lead to the loss of the guarantee, as well as the invalidation of the certifications to which submitted from the team.*

An excess of any compound (total chlorine, turbidity, hardness, etc...) can cause a reduction in the life of filters and certain components. These maintenance are indicative.

Your distributor will anticipate the duration of the consumables depending on the characteristics of the water to be treated and the expected consumption in each case.

! **ATTENTION:** *All consumables are supplied in individual packaging specially designed to guarantee hygienic conditions for storage and transport. Exercise extreme hygiene precautions after removing the consumables from their packaging and when handling the various connectors and components.*

! **ATTENTION:** *Before dismantling the equipment, provide all the material you will need to carry out maintenance operations (read section 5 Installation) and the space necessary for this. Work in a well-lit place, in adequate hygienic conditions and with enough space to carry out operations comfortably.*

- Carry out the filter change properly. Ensure the tightness of the joints and the original hydraulic configuration of the system as recommended by the manufacturer.
- Sanitize the equipment following the indications described in the Sanitation Procedure.
- For more information, see the data sheet of the team. If you have any other questions, consult your dealer.

! **ATTENTION:** *Use gloves or appropriate personal protection measures if you use chemicals during sanitization.*

HYDRAULIC DIAGRAM

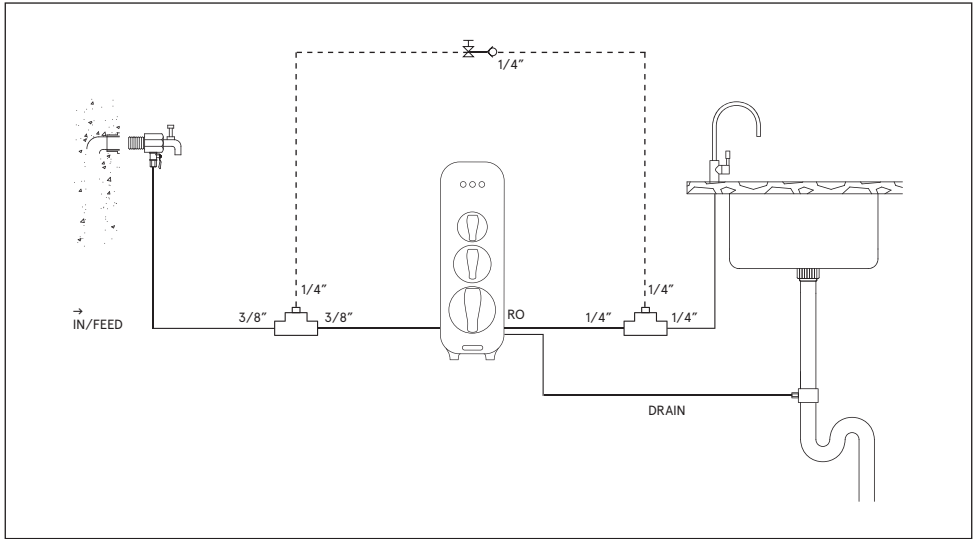

SANITIZING PROCEDURE

1. SANITIZING

Necessary material:

- Manual valve.
- Dosing cup and connectors.
- Oxibac (0.5 l).
- Brush.
- Single-use vinyl gloves.
- Easy-rinse soap or detergent.
- Food lubricant.
- Hydrogen peroxide detector strips.
- Sanitizing spray.
- Paper napkin.

Carry out a sanitization of the equipment during start-up, when appropriate (whenever there is a risk of contamination of the equipment by handling components in contact with water) or with the indicated period of time. To do this, follow the steps below:

! *ATTENTION: The water used during sanitation must be drinking water (from the public distribution network complying with the corresponding potability requirements of RD 140/2003, European directive 98/83 or current local legislation).*

- Open the tap and let water recirculate in order to renew the water inside the equipment.
- Close the inlet valve (1) and open the dispenser tap (2) to decrease the pressure in the equipment.

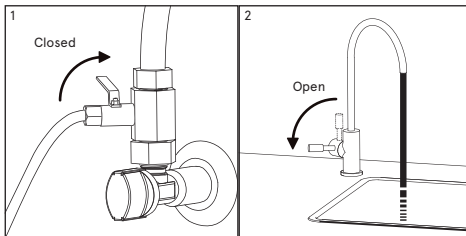

• Change the filters and wash them as indicated in the corresponding section of the equipment's Technical Manual. The sanitization must be carried out with the new pre-filters and post-filters installed and previously rinsed in an adequate way (the carbon dust from them has been correctly removed).

• Use single (3) use vinyl gloves to handle sanitizing products.

! *ATTENTION: Take extra hygiene measures when handling the filters, the membrane and the equipment components in contact with water. Use disposable gloves or wash your hands as many times as necessary to avoid risks of contamination of the equipment.*

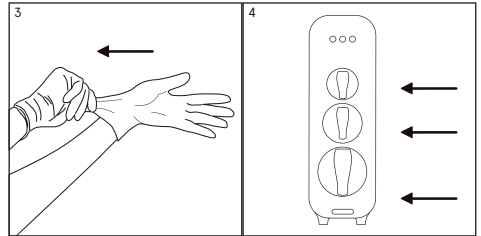

• To sanitize the equipment, the filters must be inside their housings (4).

2. PRE-FILTER, MEMBRANE AND POST-FILTER TREATMENT

• Disconnect the inlet hose to the equipment marked "feed-in", and insert the measuring cup between the stopcock and the equipment's water inlet (6). For greater comfort and ease of access during sanitization and the inlet valve opening and closing operations, you can insert, together with the sanitizing dosing cup, a manual valve in the closed position, which will perform the same functions as the manual inlet shut-off valve to the equipment.

• Once the assembly is installed, keep the new manual inlet valve closed and open the inlet valve connected to the wall adapter (7). The measuring cup must be empty.

• Pour 0.25 liters of Oxibac into the dosing cup inserted at the inlet of the equipment (8). Screw the glass correctly to its head.

• The manual inlet valve and the tap must be closed. Connect the equipment to the electrical supply.

• Open the water inlet stopcock to the equipment and to the tap, allowing it to start working and allowing the sanitizing product to suck into it. Fill a 1L jug with tap water. Before closing the tap, close the inlet valve again to lower the pressure. Refill the dispenser with 0.25l of hydrogen peroxide and empty 1 more liter of water. Close the tap. At this time the entire circuit contains sanitizing liquid.

• After 10 mins. open the dispenser tap (9) and let the tap water circulate for 5 minutes.

· Empty the measuring cup. Before opening it, have at hand a container where you can empty it, as it may be full of water.

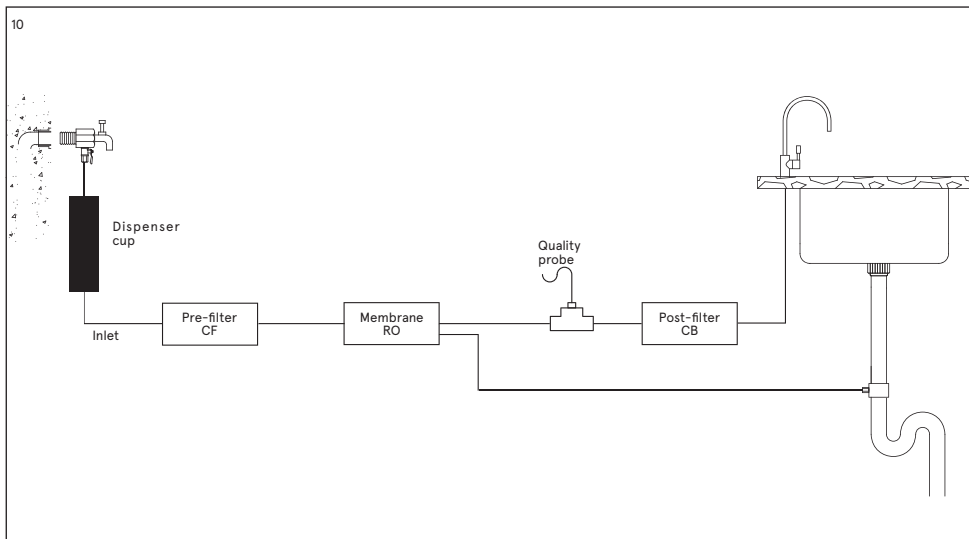
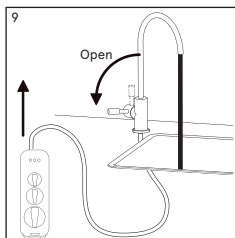
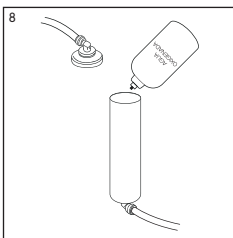
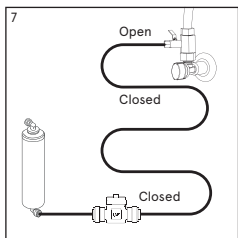
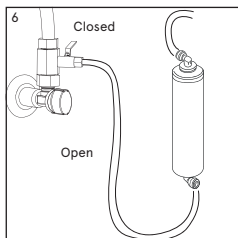

- Pay special attention to sanitizing the tap spout. Use the sanitizing spray (or, failing that, hydrogen peroxide, dosing it in such a way that it penetrates the tap) and single-use kitchen paper. Spray the spray on the tap nozzle (11), rub the spout and tap nozzle with the disposable paper and do not touch it directly with your hands (12).

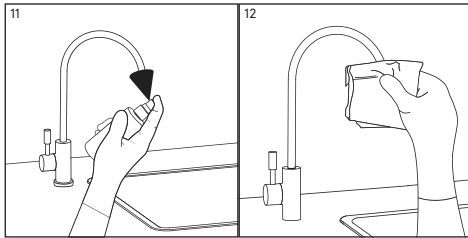

3. RINSE

- Since sanitization and rinsing do not ensure the complete removal of carbon dust from new filters or of sanitization residues, rinse the osmosis equipment with abundant water, after each sanitization, circulating mains water of adequate quality during 5 minutes or more. Discard the first 5 liters of water before consuming it.
- Rinse the pre-filter each time it is replaced and prior to each sanitization of the equipment.
- Rinse the pre-filter, preferably isolated from the rest of the equipment even before its installation.
- Rinse with plenty of water that complies with local applicable regulations regarding water potability parameters.
- Fill the pre-filter slowly in order to evacuate the contained air and avoid internal turbulence that may alter the different stages of filtration. When the water comes out of the outlet opening, gradually increase the flow rate. Draw at least 4L and make sure this water no longer contains fines from charcoal.
- Maintain, throughout the process, the filter in the same position it will occupy once installed in the equipment.
- At the end, take a blotting paper, dry all the parts that may have gotten wet and especially the Aquastop leak detection probe (if the equipment incorporates it).

DATA SHEET

REVERSE OSMOSIS EQUIPMENTS

1. TECHNICAL SPECIFICATIONS

APPLICATION

Water treatment
Reverse osmosis

Use
Improvement of the drinking water specifications (that complies with the requirements of the European Directive on water for human consumption 98/93 or its national transpositions in the different member states of the European Community).

Modifications for reduction or contribution

- Water treatment by reverse osmosis is capable of reducing concentration of salts and other substances in high percentages.
- Minimal reduction* of certain compounds and parameters:

Sodium: 90%.
Calcium: 90%.
Sulfate: 90%.
Chloride: 90%.
Total hardness: 90%.
Conductivity: 90%.

* Depending of the characteristics of water to be treated (at the membrane outlet). These values may vary depending on the type of post-filter that the equipment incorporates and / or regulation of the mixing valve (if it is included).

WORKING LIMITS

PUMP SYSTEM

Pressure (max./min.):	4 bar - 1 bar (400kPa-100kPa).
TDS (max.):	1500ppm.
Temperature (max./min.):	38 °C - 5 °C.
Hardness (max.):	15 °HF. **

Control type: Maximum pressure switch.
Inlet control bypass solenoid valve.
Flushing solenoid valve.

Security system: Minimum pressure switch.
Electronic leak sensor.
Water quality control.
Maintenance notice.

Dimensions (A x B x C in mm): 414 x 130 x 445.
Weight (in kg, including all accessories): 12,45.

Inlet connection: 3/8".
Drain connection: 1/4".
Tap connection: 1/4".
Wall adapter: 3/8" M-F. *****
Drain collar: Tube clamp
40 mm drain.

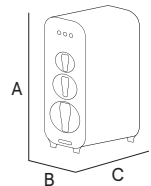
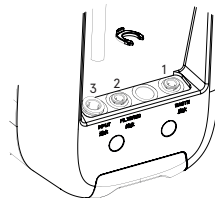

1. Drain
2. Tap
3. Inlet

CF Pre-filter

Sediments+carbon x1



RO Membrane

600 GPD Membrane x1

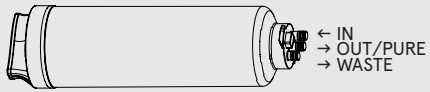

RO water flow: 1,7 lpm.
RO water volume: 4.000 l.
Optimal working pressure: 2bar.

CB Post-filter

Carbon post-filter x1

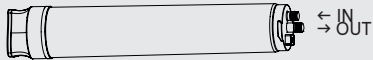

Electrical power supply:

24 VDC 75W.

Electric adapter:

100-240 Vac 50 / 60 Hz: 24 Vdc.

Faucet type:

Smart faucet.

Production:

1,7 lpm.

Membrane cleaning system:

Automatic autoflushing

HYDRAULIC DIAGRAM

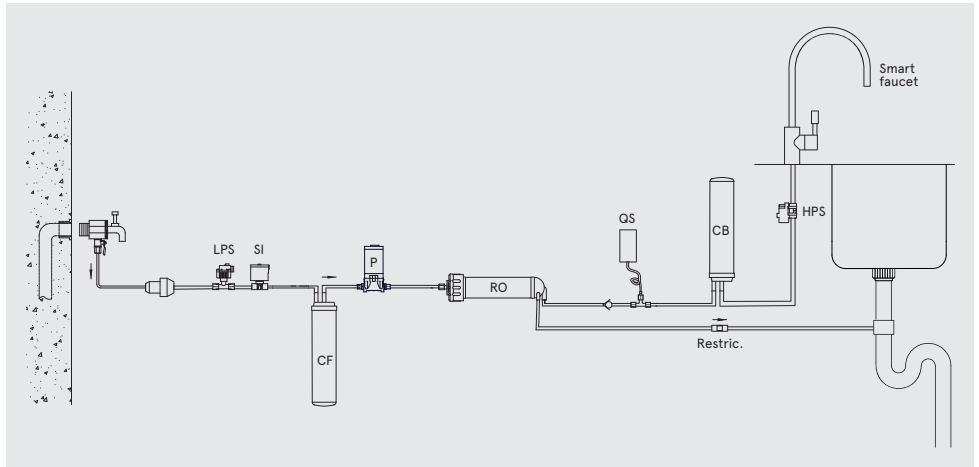

HYDRAULIC CONNECTION DIAGRAM

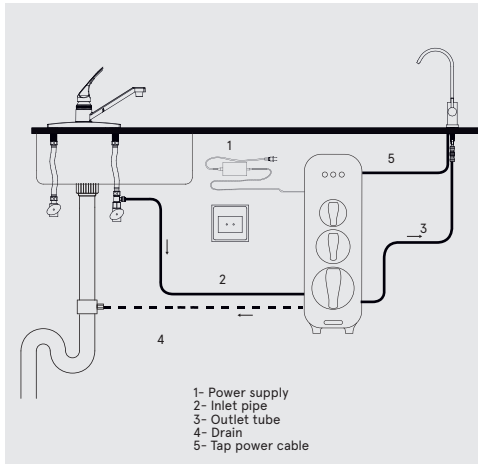

* For salinities higher than 1500ppm consult your distributor.

** Higher hardnesses may reduce the life and performance of certain components.

*** Maximum accumulation as a function of inlet pressure.

**** Flow rates can vary by 20% depending on the temperature, pressure and specific composition of the water to be treated.

***** May vary depending on the model.

DISTRIBUTED BY:

WLG (B-60326279)

Aiguafreda, 8

Pol. Ind. L'Ametlla Park

08480, L'Ametlla del Vallès

Barcelona - Spain

2. WORKING

· The mains water to be treated enters the equipment through the pre-filtration stage that incorporates a GAC (CF) turbidity and carbon filter. In this filtration stage, suspended particles, chlorine, its derivatives and other organic substances are retained.

· The equipment incorporates a minimum pressure switch to protect the pump against pressure drops in the network (LPS).

· The passage of water into the equipment is controlled by a cut-off solenoid valve (Si).

· The water, after being treated in the filtration stage, is driven towards the reverse osmosis (RO) membrane. The equipment incorporates a pump (P) to increase the pressure. The pressure of the water on the membrane makes the reverse osmosis process possible.

· Before leaving the tap, the water passes through the carbon post-filter, which improves the taste.

· Reject water or water with excess salts and other dissolved substances is directed to the drain for disposal.

· Direct flow equipment controls start and stop using a pressure switch (HPS)

· The equipment incorporates different functional and / or security systems, managed by a state-of-the-art electronic module:

· Electronic leak detection system (L). When the system detects this situation, it blocks the equipment by emitting an acoustic and light signal informing about it. The equipment will remain locked until the detection probe is dry.

· Probe for estimating the conductivity of the produced water to assess the state of the membrane and components (Q). When dispensing water from the tap, the

system will measure the conductivity of the produced water.

· Automatic filter change notice, in order to inform the user that proper maintenance must be carried out to guarantee the quality of the water dispensed.

To guarantee the quality of the water dispensed, the equipment must undergo periodic maintenance, so it will stop supplying water until it is done. One month in advance the team will notify you that the useful life of the filters is about to run out.

See more details in section 3.4 of this manual.

3. INTERFACE. SYSTEM STATUS

Display:

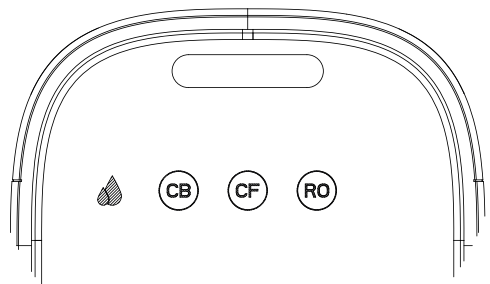

3.1 COLORS OF THE WATER QUALITY INDICATOR

· Blue: TDS≤400ppm

· Brown: 400ppm < TDS ≤ 500ppm

· Red: TDS > 500ppm

3.2. FUNCTIONALITIES

FUNCTION	ACTIONS	LIGHTS STATUS
1. Functional washing for the first use.	The machine will wash the RO membrane for 5 minutes. The tap must then be turned on for 30 minutes to rinse the production from the membrane and CB filter.	During washing, the water quality light is flashing red at 1Hz. After 6 minutes, the water quality light will return to the live measurement state.
2. Washing when turning on the machine.	Whenever the system is started it will wash the RO membrane for 20 seconds. If the user opens the tap, the machine will stop washing and go into normal mode.	When washing is in progress, the water quality light shows the previous on status.
3. Washing when accumulating operating time.	Every time the accumulated working time reaches 2 hours, the system will wash the membrane for 20 seconds. If the user opens the tap, the machine will stop the wash and go into normal mode.	When washing is in progress, the water quality light shows the previous washing status.
4. Daily washing.	When the machine has not been running for 24 hours, the system will wash the membrane for 20 seconds. If the user opens the tap, the machine will stop washing and go into normal mode.	When washing is in progress, the water quality light shows the previous washing status.
5. Washing after filter changing.	<p>CF: By changing the CF pre-filter and resetting its usage counter, the system will start a wash of the CF filter and RO membrane for 5 minutes.</p> <p>RO: By changing the RO membrane and resetting its counter, the equipment will wash the membrane for 5 minutes. Next, the tap should be turned on for 30 minutes to rinse the production from the membrane.</p> <p>CB: When changing the CB post-filter and resetting its usage counter, the filter must be washed by turning on the tap for 15 minutes.</p>	<p>When the RO membrane is being washed, the water quality light shows red and will flash at 1Hz.</p> <p>When any other filter is washed, the water quality light shows real-time water quality data and flashes at 1Hz.</p>
6. Faucet opening.	The system starts up normally.	<p>During the first 30 seconds, the water quality light shows the latest quality status and is always on.</p> <p>For the next 30 seconds, the water quality light displays real-time quality data and is always on.</p>
7. Faucet closing.	The system stops producing water and goes into standby.	The water quality light turns off.
8. System starting.	The system starts up.	After connecting the power supply, a beep sounds and all the lights turn on and blink at the same time, changing from blue to purple to red. Each color is displayed for 1 second.

3.3. BUG IDENTIFICATION AND RESOLUTION

TYPE	WARNING		SOLUTION
	DISPLAY	ACOUSTIC	
1. Lack of water pressure at the inlet.	CF, CB and RO in blue.	3 beeps.	When the water pressure at the inlet returns, the system also returns to its normal state, turning off its alarm.
2. Leak inside the machine.	CF, CB and RO in red.	Beeps for 3 minutes.	When the leak is eliminated, the alarm is deactivated and it returns to the normal state.
3. Protection by pump time.	CF and RO in red.	Beeps for 3 minutes.	The pump has been working 30 minutes in a row. Disconnect and reconnect the electrical connection.
4. Protection by start / stop the bomb.	CB and CF in red.	Beeps for 5 seconds.	Disconnect and reconnect the electrical connection.
5. Low temperature protection.	CB and RO in red.	6 beeps.	Disconnect and reconnect the electrical connection.
When it detects that the equipment is in any of the states described, contact the maintenance service to make an appointment to carry out the required maintenance. See the corresponding section in the <i>Technical manual</i> . Contact your technical service if the equip-	ment does not stop production (filling the tank) after several hours of continuous operation, without the extraction of water. Contact your technical service if the equipment is repeatedly blocked due to lack of mains water pressure at its inlet and there is pressure in the rest of the home. Contact your technical service if after open-	ing the tap the equipment is at rest without dispensing water through the tap or displaying any type of alarm. Contact your technical service to reset the counters after changing the filters.	

3.4. 3.4. FILTER LIFETIME DISPLAY

PERIOD OF LIFE	LIFE TIME (DAYS)	CAPACITY LITERS REMAINING	WARNING	
			DISPLAY	ACOUSTIC
Normal.	> 30	> 300	Permanent blue.	Without alarm.
Almost exhausted.	$0 < X \leq 30$	$0 < Y \leq 300$	Permanent brown.	Double beep when there is little time left for the filters.
Exhausted.	≤ 0	≤ 0	Permanent red.	The equipment stops supplying water because cannot guarantee its optimal quality. Perform maintenance by an authorized technical service.

3.5 SMART FAUCET STATUS INDICATORS

The smart faucet replicates on its outer ring the status of the filters that are seen on the equipment display (CF, RO and CB). The droplet symbol replicates the status of the water quality indicator LED.

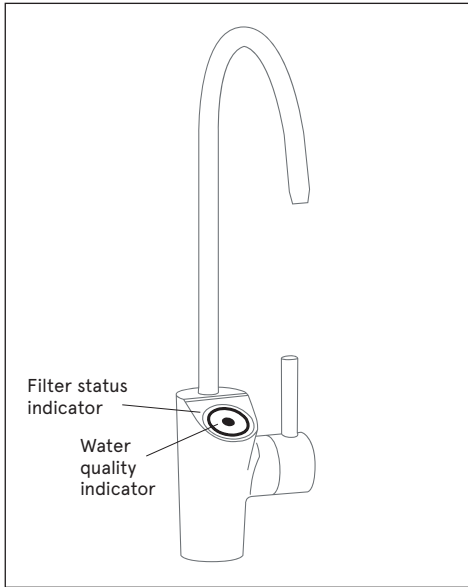

DISPENSED WATER QUALITY



BLUE / MAGENTA / RED

BLUE: right TDS in dispensed water.
MAGENTA: medium TDS in dispensed water.
RED: high TDS in dispensed water.

FLUSHING



BLINKING BLUE

Blinking indicator while the unit is flushing the membrane.

FILTER LIFESPAN STATUS



BLUE / MAGENTA / RED

BLUE: working properly.
MAGENTA: a maintenance will be required soon.
RED: the spanlife of some filter has expired.

4. WARRANTY

The distributor guarantees the equipment for a period of two years in the event of any non-compliance detected in the equipment, in accordance with Royal Decree 1/2007 of 16 November (revised text of the General Law for the Defence of Consumers and Users).

- The guarantee includes the repair and replacement of faulty parts by personnel authorised by the distributor or by the official technical assistance service (S.A.T.) at the place of installation or in its workshops. Included in the warranty is labor and shipping costs that may be generated.

- The distributor is exonerated from providing a guarantee in the case of parts subject to natural wear, lack of maintenance, blows or other nonconformities resulting from improper use of the equipment or inadequate according to the conditions and operating limits indicated by the manufacturer of the same. Likewise, the warranty becomes ineffective in cases of improper handling and use of the equipment or in those cases in which they have been modified or repaired by personnel outside the distribution company or official S.A.T..

- The parts replaced under warranty will remain the property of the distributor.

- The distributor is responsible for the lack of conformity of the equipment when it refers to the origin, identity or suitability of the products, according to their nature and purpose. Bearing in mind the characteristics of the equipment it is essential for the warranty to cover the lack of conformity, the fulfillment of the technical conditions of installation and operation. Failure to comply with these conditions may result in the absence of a warranty, taking into account the relevance of the destination of the equipment and the conditions and operating limits in which it must operate.

- The distributor must ensure that the installed equipment is suitable for improving the quality of the water to be treated in particular, according to the characteristics of the equipment and the regulations in force.

- The distributor must ensure the correct installation and start-up of the equipment as indicated by the manufacturer and current regulations and will also be liable for any lack of conformity resulting from incorrect application, installation or start-up of the equipment.

- For any warranty claim it is necessary to present the purchase invoice. The period of two years is calculated from the purchase of the equipment from the distributor.

- If there is a problem with your equipment during the warranty period, please contact your dealer.

The equipment is installed and operating to the customer's satisfaction and for the record:

* Pre-treatment of the equipment:

* Hardness of entry to the equipment (°F):

* TDS input to the equipment (ppm):

* TDS produced water (ppm):

* Pressure of entry to the equipment (bar):

*Result of the installation and commissioning sheet:

Correct:

Others:

The owner of the equipment has been properly and clearly informed of the use, handling and maintenance that the equipment requires to ensure its proper functioning and the quality of the water produced. A maintenance contract is offered for this purpose.

*Ref: Maintenance contract:

ACCEPTS the maintenance contract

DOES NOT ACCEPT the maintenance contract

If you need information, report a malfunction or malfunction, request for maintenance or intervention by a technician, please read the operation, troubleshooting and troubleshooting sections of this manual beforehand and contact the distributor or company that sold you your equipment.

COMPANY AND/OR AUTHORIZED INSTALLER, DATE AND SIGNATURE:

SERIAL NUMBER:



NOTE TO THE COMPANY AND/OR AUTHORIZED TECHNICIAN/INSTALLER: the data marked with the * symbol must be filled in by the installer and transcribed by him/herself from the INSTALLATION REGISTRATION sheet.



5. INSTALLATION REGISTER SHEET



NOTES TO THE TECHNICIAN/INSTALLER: read this manual carefully. If in doubt, contact your dealer's Technical Support Service (T.A.S.). The data marked with the symbol * must be filled in by the technician/installer and transcribed by him/herself to the WARRANTY page. This sheet must be kept by the installer and may be requested by the distributor in order to improve after-sales service and customer service. The technician who performs the installation and commissioning of the equipment must have adequate technical training.

INFORMATION ON THE USE OF THE EQUIPMENT:

Origin of the water to be treated:

PUBLIC SUPPLY NETWORK

OTHER _____

* Pre-treatment of the equipment: _____

* Hardness of entry to the equipment (°F): _____

* TDS of entry to the equipment (ppm): _____

* TDS produced water (ppm): _____

Inlet pressure to the equipment (bar): _____

INSTALLATION STEP CONTROL:

Pre-filter assembly: _____

Overflow installation: _____

Start-up according to protocol: _____

Checking of fittings: _____

Measurement of inlet hardness: _____

Output hardness measurement: _____

Installation of isolation by-pass: _____

Correct drainage installation: _____

Brine suction test/tank filling: _____

Leakage of the pressurised system: _____

Programming of the equipment: _____

Adjustment of residual hardness: _____

COMMENTS

* Result of installation and commissioning:

CORRECT (equipment installed and working correctly. Produced water suitable for the application).

OTHER: _____

IDENTIFICATION OF THE AUTHORISED TECHNICIAN/INSTALLER: CONFORMITY OF THE OWNER OF THE EQUIPMENT:

COMPANY AND/OR AUTHORIZED INSTALLER, DATE AND SIGNATURE:

I have been clearly informed of the use, operation and maintenance required by the installed equipment, having been offered a maintenance contract and informed of how to contact a customer service in the event of a request for information, communication of a breakdown or malfunction, request for maintenance or intervention by a technician.

Remarks: _____

*Ref: Maintenance contract: _____

ACCEPTS the maintenance contract

DOES NOT ACCEPT the maintenance contract

Model/Ref: _____

Owner: _____

Street _____

Telephone: _____

City: _____

Province: _____

C.P.: _____

SERIAL NUMBER

EQUIPMENT WARRANTY DIRECTED TO THE DISTRIBUTOR:

The distributor will only be responsible for the replacement of parts in the event of non-conformity. The repair of the equipment and the costs involved (labour, shipping costs, travel, etc.) will be borne by the distributor, in accordance with the general conditions of contract and sale, so it can not be passed on later to the manufacturer.



6. MAINTENANCE SERVICE

DATE	TYPE OF SERVICE	NAME, SIGNATURE AND STAMP OF TECHNICIAN	
<input type="text"/>	<input type="radio"/> START-UP		
<input type="text"/>	<input type="radio"/> COMPLETE MAINTENANCE	TECHNICIAN <input type="text"/>	<input type="radio"/> ORDINARY <input type="radio"/> EXTRAORDINARY <input type="radio"/> WARRANTY
<input type="text"/>	<input type="radio"/> PREPARATION	STAMP	
<input type="text"/>	<input type="radio"/> SANITIZATION	<input type="text"/>	
<input type="text"/>	<input type="radio"/> OTHERS		
<input type="text"/>			
<input type="text"/>	<input type="radio"/> COMPLETE MAINTENANCE	TECHNICIAN <input type="text"/>	<input type="radio"/> ORDINARY <input type="radio"/> EXTRAORDINARY <input type="radio"/> WARRANTY
<input type="text"/>	<input type="radio"/> PREPARATION	STAMP	
<input type="text"/>	<input type="radio"/> SANITIZATION	<input type="text"/>	
<input type="text"/>	<input type="radio"/> OTHERS		
<input type="text"/>			
<input type="text"/>	<input type="radio"/> COMPLETE MAINTENANCE	TECHNICIAN <input type="text"/>	<input type="radio"/> ORDINARY <input type="radio"/> EXTRAORDINARY <input type="radio"/> WARRANTY
<input type="text"/>	<input type="radio"/> PREPARATION	STAMP	
<input type="text"/>	<input type="radio"/> SANITIZATION	<input type="text"/>	
<input type="text"/>	<input type="radio"/> OTHERS		
<input type="text"/>			
<input type="text"/>	<input type="radio"/> COMPLETE MAINTENANCE	TECHNICIAN <input type="text"/>	<input type="radio"/> ORDINARY <input type="radio"/> EXTRAORDINARY <input type="radio"/> WARRANTY
<input type="text"/>	<input type="radio"/> PREPARATION	STAMP	
<input type="text"/>	<input type="radio"/> SANITIZATION	<input type="text"/>	
<input type="text"/>	<input type="radio"/> OTHERS		
<input type="text"/>			
<input type="text"/>	<input type="radio"/> COMPLETE MAINTENANCE	TECHNICIAN <input type="text"/>	<input type="radio"/> ORDINARY <input type="radio"/> EXTRAORDINARY <input type="radio"/> WARRANTY
<input type="text"/>	<input type="radio"/> PREPARATION	STAMP	
<input type="text"/>	<input type="radio"/> SANITIZATION	<input type="text"/>	
<input type="text"/>	<input type="radio"/> OTHERS		
<input type="text"/>			

6. MAINTENANCE SERVICE

DATE	TYPE OF SERVICE	NAME, SIGNATURE AND STAMP OF TECHNICIAN	
<input type="text"/>	<input type="radio"/> START-UP		
<input type="text"/>	<input type="radio"/> COMPLETE MAINTENANCE	TECHNICIAN <input type="text"/>	<input type="radio"/> ORDINARY <input type="radio"/> EXTRAORDINARY <input type="radio"/> WARRANTY
<input type="text"/>	<input type="radio"/> PREPARATION	STAMP	
<input type="text"/>	<input type="radio"/> SANITIZATION	<input type="text"/>	
<input type="text"/>	<input type="radio"/> OTHERS		
<input type="text"/>	<input type="radio"/> COMPLETE MAINTENANCE	TECHNICIAN <input type="text"/>	<input type="radio"/> ORDINARY <input type="radio"/> EXTRAORDINARY <input type="radio"/> WARRANTY
<input type="text"/>	<input type="radio"/> PREPARATION	STAMP	
<input type="text"/>	<input type="radio"/> SANITIZATION	<input type="text"/>	
<input type="text"/>	<input type="radio"/> OTHERS		
<input type="text"/>	<input type="radio"/> COMPLETE MAINTENANCE	TECHNICIAN <input type="text"/>	<input type="radio"/> ORDINARY <input type="radio"/> EXTRAORDINARY <input type="radio"/> WARRANTY
<input type="text"/>	<input type="radio"/> PREPARATION	STAMP	
<input type="text"/>	<input type="radio"/> SANITIZATION	<input type="text"/>	
<input type="text"/>	<input type="radio"/> OTHERS		
<input type="text"/>	<input type="radio"/> COMPLETE MAINTENANCE	TECHNICIAN <input type="text"/>	<input type="radio"/> ORDINARY <input type="radio"/> EXTRAORDINARY <input type="radio"/> WARRANTY
<input type="text"/>	<input type="radio"/> PREPARATION	STAMP	
<input type="text"/>	<input type="radio"/> SANITIZATION	<input type="text"/>	
<input type="text"/>	<input type="radio"/> OTHERS		
<input type="text"/>	<input type="radio"/> COMPLETE MAINTENANCE	TECHNICIAN <input type="text"/>	<input type="radio"/> ORDINARY <input type="radio"/> EXTRAORDINARY <input type="radio"/> WARRANTY
<input type="text"/>	<input type="radio"/> PREPARATION	STAMP	
<input type="text"/>	<input type="radio"/> SANITIZATION	<input type="text"/>	
<input type="text"/>	<input type="radio"/> OTHERS		

6. MAINTENANCE SERVICE

DATE	TYPE OF SERVICE	NAME, SIGNATURE AND STAMP OF TECHNICIAN	
<input type="text"/>	<input type="radio"/> START-UP		
<input type="text"/>	<input type="radio"/> COMPLETE MAINTENANCE	TECHNICIAN <input type="text"/>	<input type="radio"/> ORDINARY <input type="radio"/> EXTRAORDINARY <input type="radio"/> WARRANTY
<input type="text"/>	<input type="radio"/> PREPARATION	STAMP	
<input type="text"/>	<input type="radio"/> SANITIZATION	<input type="text"/>	
<input type="text"/>	<input type="radio"/> OTHERS		
<input type="text"/>	<input type="radio"/> COMPLETE MAINTENANCE	TECHNICIAN <input type="text"/>	<input type="radio"/> ORDINARY <input type="radio"/> EXTRAORDINARY <input type="radio"/> WARRANTY
<input type="text"/>	<input type="radio"/> PREPARATION	STAMP	
<input type="text"/>	<input type="radio"/> SANITIZATION	<input type="text"/>	
<input type="text"/>	<input type="radio"/> OTHERS		
<input type="text"/>	<input type="radio"/> COMPLETE MAINTENANCE	TECHNICIAN <input type="text"/>	<input type="radio"/> ORDINARY <input type="radio"/> EXTRAORDINARY <input type="radio"/> WARRANTY
<input type="text"/>	<input type="radio"/> PREPARATION	STAMP	
<input type="text"/>	<input type="radio"/> SANITIZATION	<input type="text"/>	
<input type="text"/>	<input type="radio"/> OTHERS		
<input type="text"/>	<input type="radio"/> COMPLETE MAINTENANCE	TECHNICIAN <input type="text"/>	<input type="radio"/> ORDINARY <input type="radio"/> EXTRAORDINARY <input type="radio"/> WARRANTY
<input type="text"/>	<input type="radio"/> PREPARATION	STAMP	
<input type="text"/>	<input type="radio"/> SANITIZATION	<input type="text"/>	
<input type="text"/>	<input type="radio"/> OTHERS		
<input type="text"/>	<input type="radio"/> COMPLETE MAINTENANCE	TECHNICIAN <input type="text"/>	<input type="radio"/> ORDINARY <input type="radio"/> EXTRAORDINARY <input type="radio"/> WARRANTY
<input type="text"/>	<input type="radio"/> PREPARATION	STAMP	
<input type="text"/>	<input type="radio"/> SANITIZATION	<input type="text"/>	
<input type="text"/>	<input type="radio"/> OTHERS		

6. MAINTENANCE SERVICE

DATE	TYPE OF SERVICE	NAME, SIGNATURE AND STAMP OF TECHNICIAN	
<input type="text"/>	<input type="radio"/> START-UP		
<input type="text"/>	<input type="radio"/> COMPLETE MAINTENANCE	TECHNICIAN <input type="text"/>	<input type="radio"/> ORDINARY <input type="radio"/> EXTRAORDINARY <input type="radio"/> WARRANTY
<input type="text"/>	<input type="radio"/> PREPARATION	STAMP	
<input type="text"/>	<input type="radio"/> SANITIZATION	<input type="text"/>	
<input type="text"/>	<input type="radio"/> OTHERS		
<input type="text"/>	<input type="radio"/> COMPLETE MAINTENANCE	TECHNICIAN <input type="text"/>	<input type="radio"/> ORDINARY <input type="radio"/> EXTRAORDINARY <input type="radio"/> WARRANTY
<input type="text"/>	<input type="radio"/> PREPARATION	STAMP	
<input type="text"/>	<input type="radio"/> SANITIZATION	<input type="text"/>	
<input type="text"/>	<input type="radio"/> OTHERS		
<input type="text"/>	<input type="radio"/> COMPLETE MAINTENANCE	TECHNICIAN <input type="text"/>	<input type="radio"/> ORDINARY <input type="radio"/> EXTRAORDINARY <input type="radio"/> WARRANTY
<input type="text"/>	<input type="radio"/> PREPARATION	STAMP	
<input type="text"/>	<input type="radio"/> SANITIZATION	<input type="text"/>	
<input type="text"/>	<input type="radio"/> OTHERS		
<input type="text"/>	<input type="radio"/> COMPLETE MAINTENANCE	TECHNICIAN <input type="text"/>	<input type="radio"/> ORDINARY <input type="radio"/> EXTRAORDINARY <input type="radio"/> WARRANTY
<input type="text"/>	<input type="radio"/> PREPARATION	STAMP	
<input type="text"/>	<input type="radio"/> SANITIZATION	<input type="text"/>	
<input type="text"/>	<input type="radio"/> OTHERS		
<input type="text"/>	<input type="radio"/> COMPLETE MAINTENANCE	TECHNICIAN <input type="text"/>	<input type="radio"/> ORDINARY <input type="radio"/> EXTRAORDINARY <input type="radio"/> WARRANTY
<input type="text"/>	<input type="radio"/> PREPARATION	STAMP	
<input type="text"/>	<input type="radio"/> SANITIZATION	<input type="text"/>	
<input type="text"/>	<input type="radio"/> OTHERS		

NOTES

NOTES
