

PLURIJET 90X-130X-200X

Self-priming multi-stage pumps



IMPELLERS
Noryl FE1520PW

 Clean water

 Domestic use

 Civil use



PERFORMANCE RANGE

- Flow rate up to **200 l/min** (12 m³/h)
- Head up to **97 m**

APPLICATION LIMITS

- Manometric suction lift up to **9 m** (HS)
- Liquid temperature between **-10 °C** and **+40 °C**
- Ambient temperature up to **+40 °C**
- Max. working pressure **10 bar**
- Continuous service **S1**

CONSTRUCTION AND SAFETY STANDARDS

EN 60335-1
IEC 60335-1
CEI 61-150

EN 60034-1
IEC 60034-1
CEI 2-3



CERTIFICATIONS

Company with management system certified DNV
ISO 9001: QUALITY



INSTALLATION AND USE

The self-priming **PLURIJET** pumps are recommended for pumping clean water even in cases where air is present and for liquids which are not chemically aggressive towards the materials from which the pump is made.

Because of their silence, reliability and low energy consumption they are recommended for domestic and civil applications, in particular for pressurising and distributing water in combination with pressure tanks, for the recovery of rain water, for irrigation systems, etc.

The pump should be installed in an enclosed environment or sheltered from inclement weather.

PATENTS - TRADE MARKS - MODELS

- Registered Trade Mark n. 3974301 PLURIJET®
- Patent Pending n. PCT/IB2014/063126

OPTIONS AVAILABLE ON REQUEST

- Other voltages or 60 Hz frequency
- IPX5 class protection

CHARACTERISTIC CURVES AND PERFORMANCE DATA

50 Hz n = 2900 min⁻¹ HS = 0 m

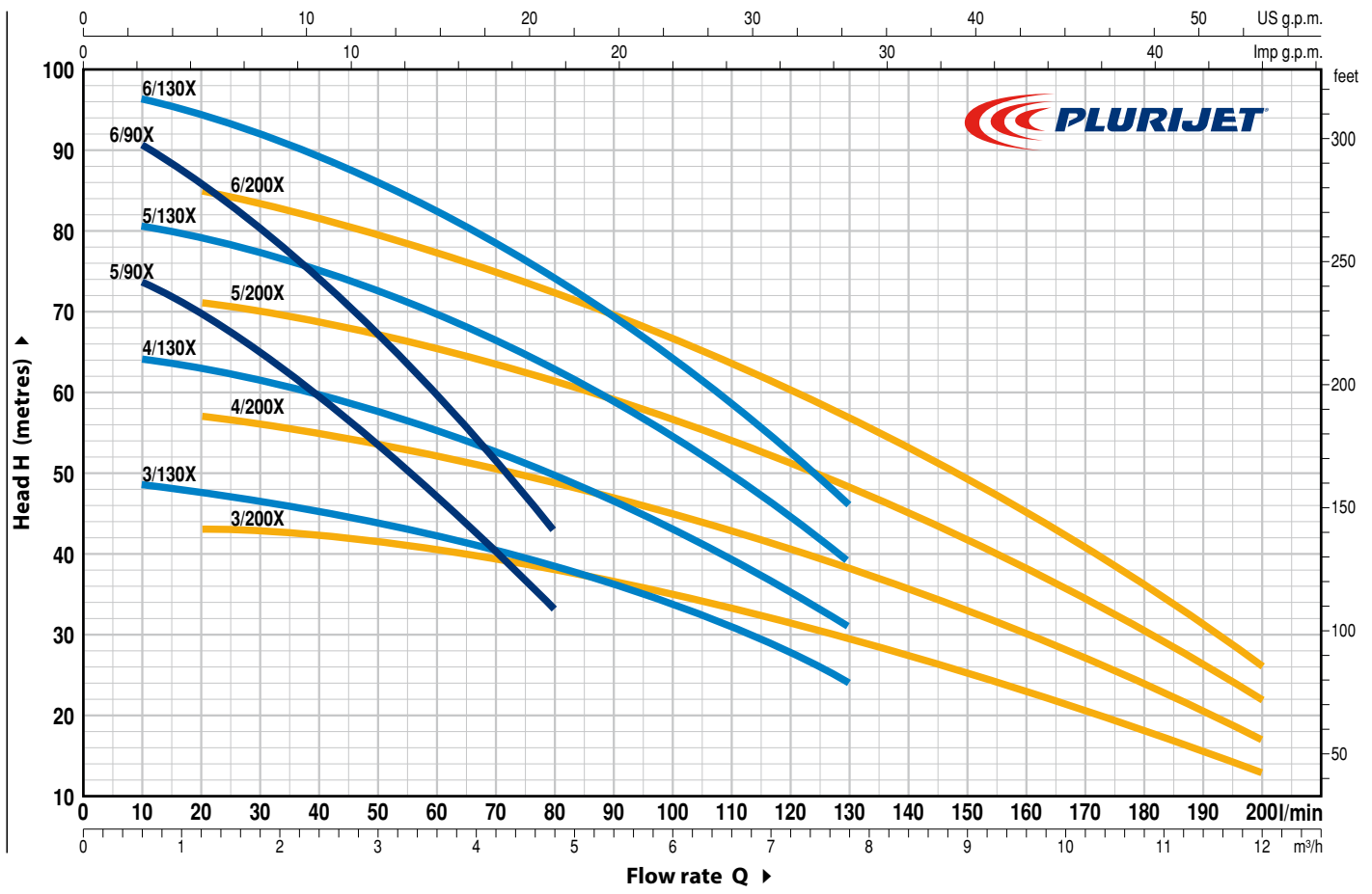

MODEL		POWER (P ₂)		Q	Flow rate (m³/h)													
Single-phase	Three-phase	kW	HP		0	0.3	0.6	1.2	2.4	3.6	4.8	6.0	7.8	8.4	9.6	10.8	12.0	
PLURIJETm 5/90X	PLURIJET 5/90X	1.1	1.5	IE3	76	76	73.5	70	60.5	47	33							
PLURIJETm 6/90X	PLURIJET 6/90X	1.5	2		93	93	90.5	86	74.5	59.5	43							
PLURIJETm 3/130X	PLURIJET 3/130X	1.1	1.5		49	49	48.5	47.5	45	42.5	38.5	33.5	24					
PLURIJETm 4/130X	PLURIJET 4/130X	1.5	2		65	65	64	63	60	56	50	43	31					
PLURIJETm 5/130X	PLURIJET 5/130X	1.8	2.5		81	81	80.5	79	75	70	62.5	54	39					
-	PLURIJET 6/130X	2.2	3		97	97	96.5	94.5	90	83	74.5	64	46					
PLURIJETm 3/200X	PLURIJET 3/200X	1.1	1.5		44	43.5	43.5	43	42	40.5	38	35	29	27.5	23	18	13	
PLURIJETm 4/200X	PLURIJET 4/200X	1.5	2		58	57.5	57.5	57	55	52.5	49.5	45	38	35.5	30	24	17	
PLURIJETm 5/200X	PLURIJET 5/200X	1.8	2.5		73	72	71.5	71	69	65.5	62	56.5	48	44.5	38	30	22	
-	PLURIJET 6/200X	2.2	3		87	86	85.5	85	82	78	73	67	57	53	45	36	26	

Q = Flow rate H = Total manometric head HS = Suction height

Tolerance of characteristic curves in compliance with EN ISO 9906 Grade 3B.

▲ Performance class of the three-phase motor (IEC 60034-30-1)

STANDARD INSTALLATION

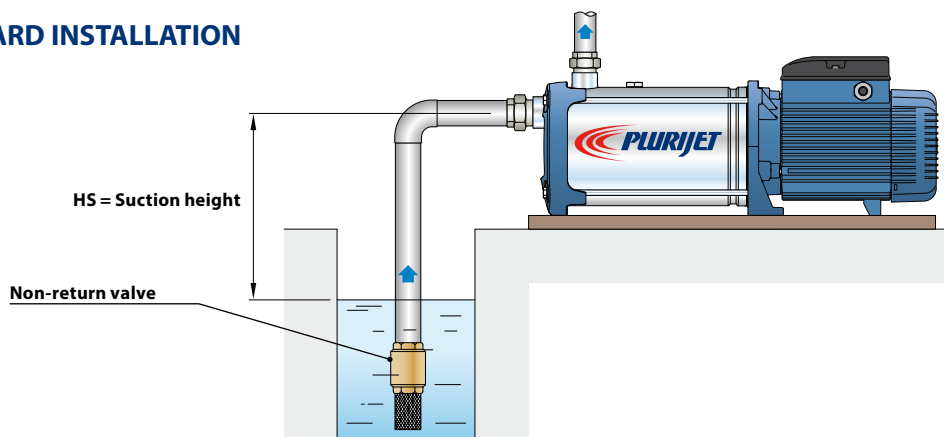

PLURIJET 90X-130X-200X

POS. COMPONENT CONSTRUCTION CHARACTERISTICS

1	PUMP BODY	Stainless steel AISI 304 complete with threaded ports in compliance with ISO 228/1				
2	BODY BACKPLATE	Stainless steel AISI 304				
3	IMPELLERS	Noryl FE1520PW				
4	DIFFUSERS	Stainless steel AISI 304				
5	MOTOR SHAFT	Stainless steel EN 10088-3 - 1.4104				
6	MECHANICAL SEAL	Seal	Shaft	Materials		
		<i>Model</i>	<i>Diameter</i>	<i>Stationary ring</i>	<i>Rotational ring</i>	<i>Elastomer</i>
		FN-18	Ø 18 mm	Graphite	Ceramic	NBR
7	BEARINGS	6304 2RS - C3 / 6204 ZZ - C3E				
8	CAPACITOR	Pump	Capacitance			
		<i>Single-phase</i>	<i>(220-230 V or 240 V)</i>			
		PLURIJETm 5/90X PLURIJETm 3/130X PLURIJETm 3/200X	31.5 µF - 450 VL			
		PLURIJETm 6/90X PLURIJETm 4/130X PLURIJETm 4/200X	45 µF - 450 VL			
		PLURIJETm 5/130X PLURIJETm 5/200X	50 µF - 450 VL			
9	ELECTRIC MOTOR	<p>PLURIJETm: single-phase 220-230 V - 50 Hz with thermal overload protector incorporated into the winding. PLURIJET: three-phase 230/400 V - 50 Hz.</p> <p>⇒ The three-phase pumps are fitted with high performance motors in class IE3 (IEC 60034-30-1)</p> <ul style="list-style-type: none"> - Insulation: class F - Protection: IP X4 				

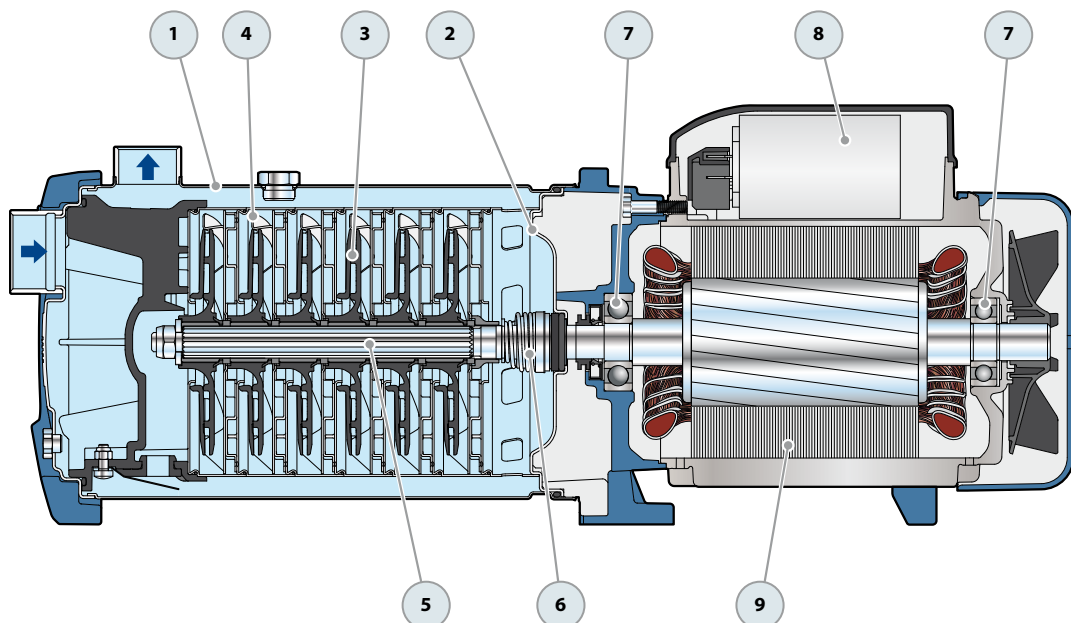

DIMENSIONS AND WEIGHT

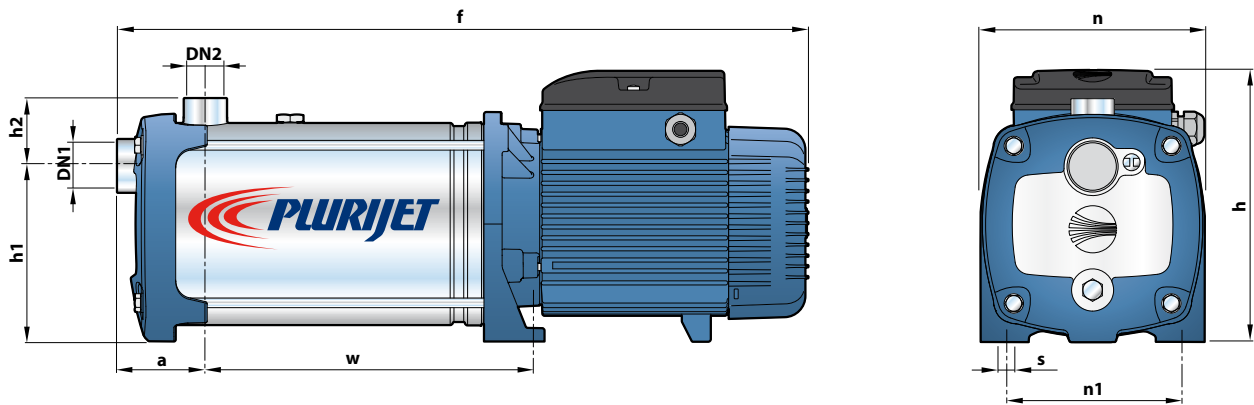

MODEL		PORTS		DIMENSIONS mm									kg	
Single-phase	Three-phase	DN1	DN2	a	f	h	h1	h2	n	n1	w	s	1~	3~
PLURIJETm 5/90X	PLURIJET 5/90X	1¼"	1"	73	492	224	145	56	185	145	245	11	19.5	17.7
PLURIJETm 6/90X	PLURIJET 6/90X				518						271		22.8	21.9
PLURIJETm 3/130X	PLURIJET 3/130X				440						193		17.7	15.8
PLURIJETm 4/130X	PLURIJET 4/130X				466						219		19.8	18.8
PLURIJETm 5/130X	PLURIJET 5/130X				512						245		23.4	23.9
-	PLURIJET 6/130X				538						271		-	24.7
PLURIJETm 3/200X	PLURIJET 3/200X				440						193		17.7	15.8
PLURIJETm 4/200X	PLURIJET 4/200X				466						219		19.8	18.8
PLURIJETm 5/200X	PLURIJET 5/200X				512						245		23.4	23.9
-	PLURIJET 6/200X				538						271		-	24.7

ABSORPTION

MODEL	VOLTAGE		
	230 V	240 V	110 V
Single-phase	230 V	240 V	110 V
PLURIJETm 5/90X	9.3 A	9.0 A	18.6 A
PLURIJETm 6/90X	11.0 A	10.5 A	22.0 A
PLURIJETm 3/130X	8.5 A	8.3 A	17.0 A
PLURIJETm 4/130X	10.3 A	9.9 A	20.6 A
PLURIJETm 5/130X	12.5 A	12.0 A	25.0 A
PLURIJETm 3/200X	8.7 A	8.0 A	17.4 A
PLURIJETm 4/200X	10.5 A	10.1 A	21.0 A
PLURIJETm 5/200X	12.5 A	12.0 A	25.0 A

MODEL	VOLTAGE					
	230 V	400 V	690 V	240 V	415 V	720 V
Three-phase	230 V	400 V	690 V	240 V	415 V	720 V
PLURIJET 5/90X	6.1 A	3.5 A	2.0 A	5.9 A	3.4 A	1.9 A
PLURIJET 6/90X	7.3 A	4.2 A	2.4 A	6.9 A	4.0 A	2.3 A
PLURIJET 3/130X	5.6 A	3.2 A	1.8 A	5.4 A	3.1 A	1.8 A
PLURIJET 4/130X	6.9 A	4.0 A	2.3 A	6.6 A	3.8 A	2.2 A
PLURIJET 5/130X	9.0 A	5.2 A	3.0 A	8.6 A	5.0 A	2.9 A
PLURIJET6/130X	9.9 A	5.7 A	3.3 A	9.5 A	5.5 A	3.2 A
PLURIJET 3/200X	5.9 A	3.4 A	2.0 A	5.7 A	3.3 A	1.9 A
PLURIJET 4/200X	7.3 A	4.2 A	2.4 A	7.0 A	4.0 A	2.3 A
PLURIJET 5/200X	9.4 A	5.4 A	3.1 A	9.0 A	5.2 A	3.0 A
PLURIJET 6/200X	10.2 A	5.9 A	3.4 A	9.8 A	5.7 A	3.3 A