

Parts and technical service guide
 Guía de servicio técnico y recambios
 Guide d'instructions et pièces de rechange
 Bedienungsanleitung und Teileliste

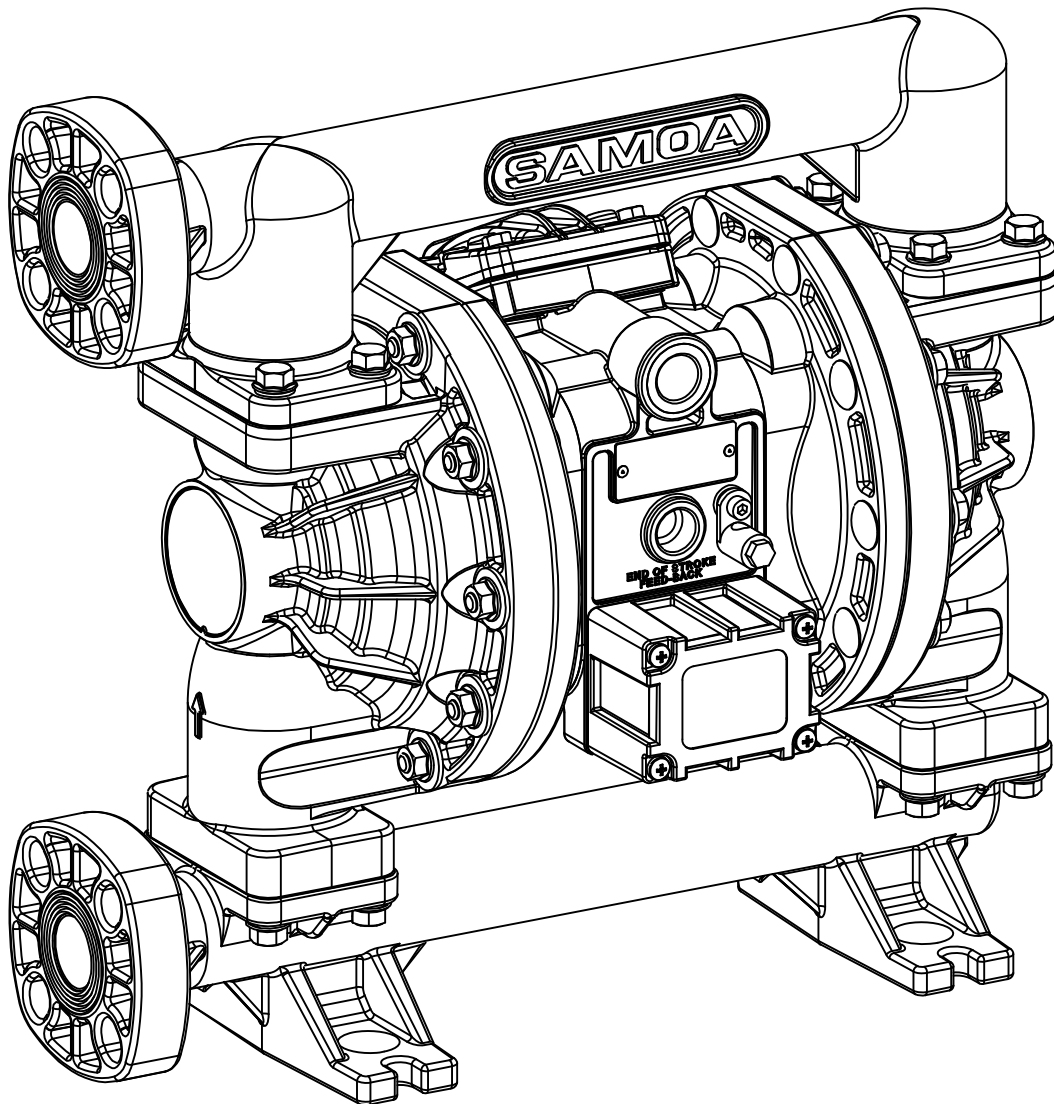

2024_02_01-10:00

EN	1" DOUBLE DIAPHRAGM NON-METALLIC PUMP UP10 (200 l/min-52 gal/min)	2
ES	BOMBA PLÁSTICA DE DOBLE DIAFRAGMA 1" UP10 (200 l/min-52 gal/min)	12
FR	POMPE À PLASTIQUE À DOUBLE MEMBRANE 1" UP10 (200 l/min-52 gal/min)	22
DE	DOPPELMEMBRAN-PLASTIKPUMPE 1" UP10 (200 l/min-52 gal/min)	30

PUMP NOMENCLATURE / NOMENCLATURA DE LA BOMBA

EN ES

PUMP NOMENCLATURE: UP10X-XXX-XXX

UP 10	X	-	X	X	X	-	X	X	X
CENTRAL BODY & AIR CHAMBERS B Conductive Polypropylene			FLUID PORTS / LOCATION Central ports: C 1" ANSI/DIN Flanged Ports B 1" BSP Threaded Ports N 1" NPT Threaded Ports Lateral ports: F 1" ANSI/DIN Flanged Ports P 1" BSP Threaded Ports T 1" NPT Threaded Ports	FLUID CHAMBERS & MANIFOLDS P Polypropylene W PVDF B Conductive Polypropylene	HARDWARE BOLTS S Stainless steel		VALVE SEATS P Polypropylene T PTFE	VALVE BALLS H Hytrel® M Santoprene® N Nitrile (Buna-N) T PTFE (Teflon®) V FKM (Viton®)	DIAPHRAGM A Santoprene® C Hytrel® G Nitrile (Buna-N) V FKM (Viton®) Two-piece: Z PTFE (Teflon®) with Santoprene® backer

NOMENCLATURA DE LA BOMBA : UP10X-XXX-XXX

UP 10	X	-	X	X	X	-	X	X	X
CUERPO CENTRAL Y CÁMARAS DE AIRE B Polipropileno conductivo			CONEXIONES / UBICACIÓN Puertos centrales: C Brida 1" ANSI/DIN B Conex. roscadas 1" BSP N Conex. roscadas 1" NPT Puertos laterales: F Brida 1" ANSI/DIN P Conex. roscadas 1" BSP T Conex. roscadas 1" NPT	CÁMARAS DE FLUIDO Y COLECTORES P Polipropileno W PVDF B Polipropileno Conductivo	TORNILLERÍA S Acero inoxidable		ASIENTOS P Polipropileno T PTFE	BOLAS H Hytrel® M Santoprene® N Nitrile (Buna-N) T PTFE (Teflon®) V FKM (Viton®)	DIAFRAGMAS A Santoprene® C Hytrel® G Nitrile (Buna-N) V FKM (Viton®) Dos piezas: Z PTFE (Teflon®) con soporte de Santoprene®

TECHNICAL DATA / DATOS TÉCNICOS

		UP10
RATIO	RATIO	1:1
MAXIMUM FREE FLOW	MÁXIMO CAUDAL SALIDA LIBRE	200 l/min. (53 Us gal/min)
DELIVERY PER CYCLE	DESPLAZAMIENTO POR CICLO	0,85 l. (0,2 gal)
AIR PRESSURE OPERATING RANGE	RANGO DE PRESIÓN	1,5 - 7 bar (20 - 100 psi)
SOLID IN SUSPENSION MAX SIZE	MAX. TAMAÑO DE PARTÍCULAS EN SUSPENSIÓN	6,4 mm (1/4")
MAXIMUM SUCTION HEAD	ALTURA MÁXIMA DE SUCCIÓN	5 m (16 ft) dry / 8 m (26 ft) wet
FLUID INLET/OUTLET CONNECTIONS	CONEXIONES DE ENTRADA/SALIDA DE FLUIDO	1" ANSI/DIN DN25 Flanged / Brida 1" BSP (F) Threaded / Roscada 1" NPT (F) Threaded / Roscada
AIR INLET	ENTRADA DE AIRE	1/2" NPT (F)
AIR EXHAUST PORT	SALIDA DE AIRE	1" NPT (F) (Optional / Opcional)
SOUND LEVEL	NIVEL SONORO	75 db (A) @ 50 cycles/ciclos / min @ 5 bar (70 psi)
WEIGHT	PESO	10,2 Kg (22,5 lb) - PP Version / Versión PP 11,6 Kg (25,6 lb) - Conductive PP Version / Versión PP conductivo 13,5 Kg (29,8 lb) - PVDF Version / Versión PVDF

(oz, ft, gal/min) all in EEUU units / todo en unidades EEUU.

PERFORMANCE CHART / GRÁFICO DE RENDIMIENTO

2024_02_01-10:00

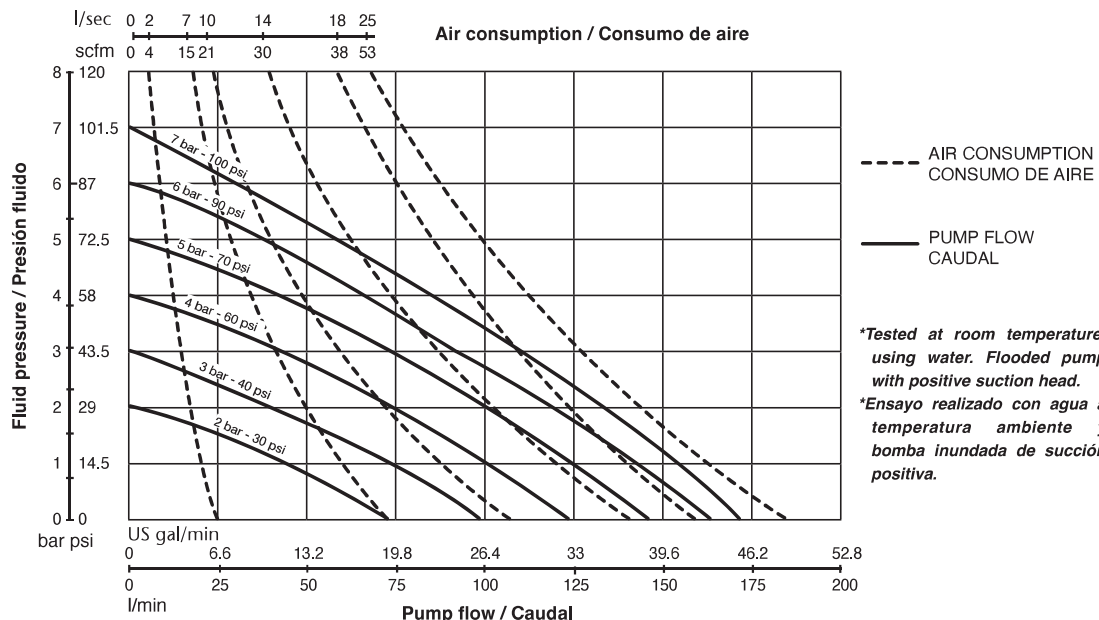

*Tested at room temperature, using water. Flooded pump with positive suction head.
*Ensayo realizado con agua a temperatura ambiente y bomba inundada de succión positiva.

DIMENSIONS / DIMENSIONES

NON-METALLIC / PLÁSTICA

Flanged outlets / Conexión de brida

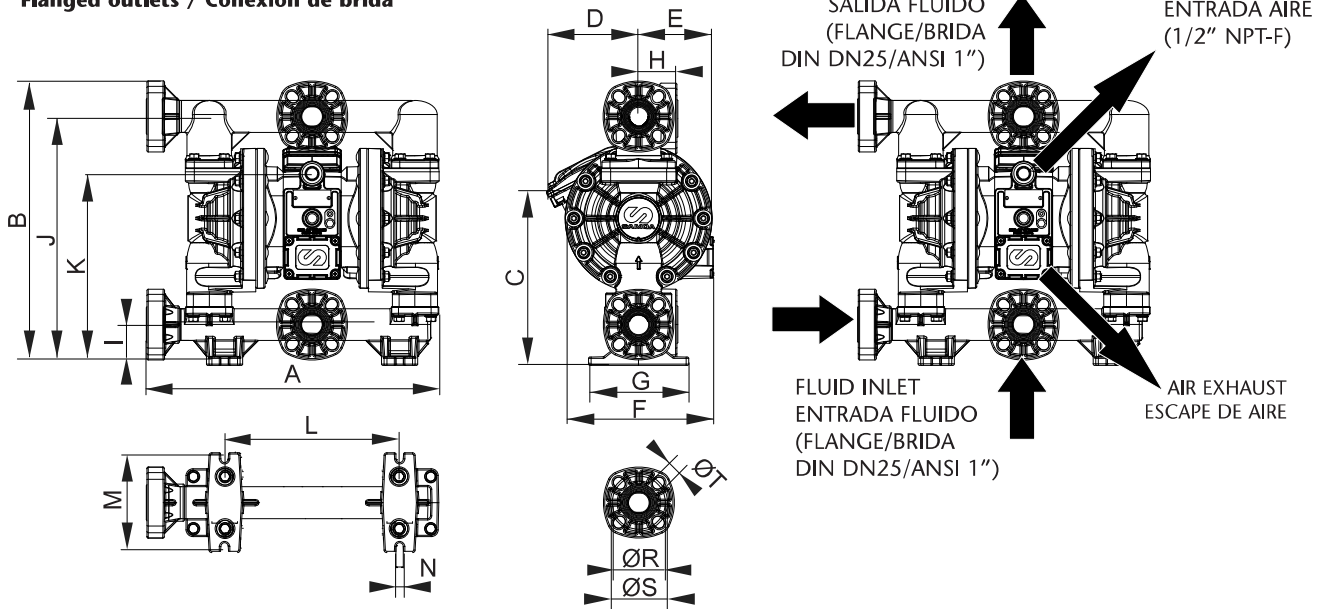

DIMENSIONS / DIMENSIONES

	A	B	C	D	E	F	G	H	I	J	K	L	M	N	R	S	T
Lateral Conn. Conex.Lateral	425	415	254	133	109	214	146	-	59	363	280	255	128	11	77,5	83,5	15
Central Conn. Conex.Central	399							56									
Lateral Conn. Conex.Lateral	16.73"	16.34"	10"	5.24"	4.29"	8.43"	5.75"	-	2.32"	14.29"	11.02"	10.04"	5.04"	0.43"	3.05"	3.29"	0.59"
Central Conn. Conex.Central	15.71"							2.20"									

Threaded outlets / Salidas roscadas

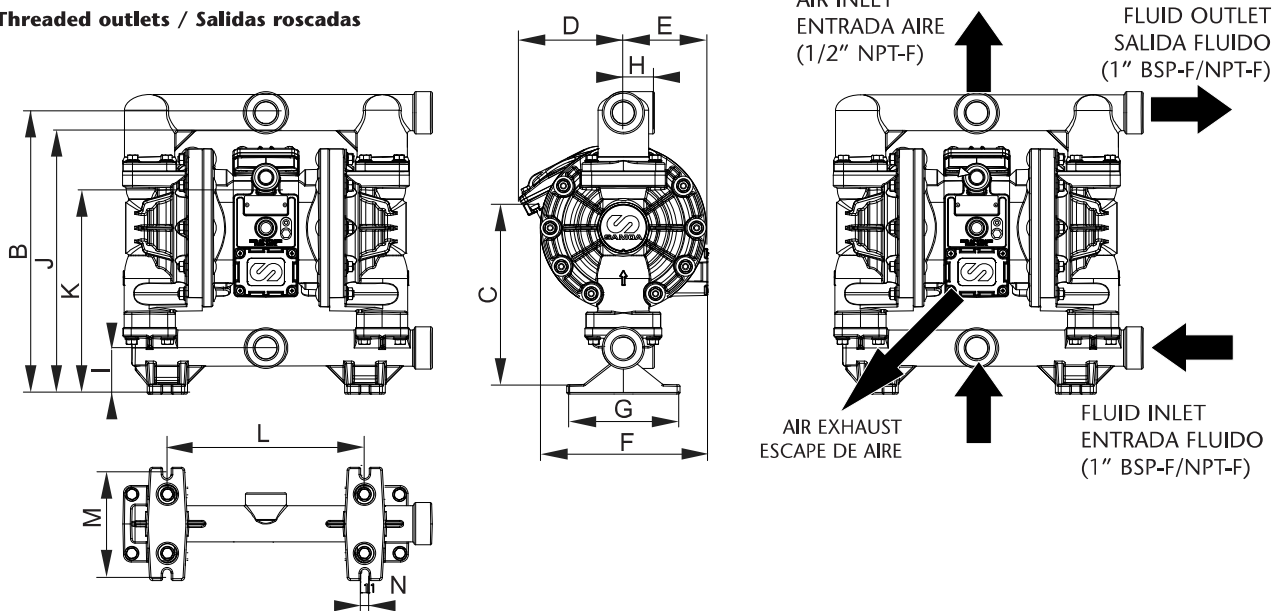

DIMENSIONS / DIMENSIONES

	A	B	C	D	E	F	G	H	I	J	K	L	M	N
Lateral Conn. Conex.Lateral	399	386	250	135	108	214	146	-	59	363	280	255	128	11
Central Conn. Conex.Central	399							40						
Lateral Conn. Conex.Lateral	15.71"	15.20"	9.84"	5.31"	4.25"	8.43"	5.75"	-	2.32"	14.29"	11.02"	10.04"	5.04"	0.43"
Central Conn. Conex.Central	15.71"							1.57"						

2024_02_01-10:00



Product pictures and specifications are subject to change without prior notice.

The English version is a translation of the original document in Spanish. In case of a discrepancy, the original will prevail.

EQUIPMENT MISUSE



- This equipment is for professional use only.
- Do not tamper the equipment.
- Use the equipment only for its intended purpose.
- Use only original replacement parts from Samoa Industrial, S.A.
- Install and use the pump following all local and national regulations including all health and safety laws and regulations.
- Avoid unnecessary damage to the pump. Do not allow the pump to run for long periods of time without fluid (dry). Disconnect the pump from the air line when the system is idle for long periods of time.

CHEMICAL COMPATIBILITIES AND TEMPERATURE LIMITS



- Chemical compatibility can change with temperature and concentration of chemicals within the fluids being pumped, discharged or circulated. For specific fluid compatibility, consult the chemical manufacturer.
- Maximum temperature limits are based upon mechanical stress only. Certain chemicals will significantly reduce maximum safe operating temperatures. Consult the chemical manufacturer for temperature limits.
- Fluids not compatible with the pump materials can cause damage to the pump and may cause serious personal injuries. Always consult your authorized Samoa supplier if you have questions regarding the pump and fluid compatibility.
- Do not exceed material temperature limits:

MATERIAL	TEMPERATURE RANGE
PTFE	-10 °C / +107°C / -14 °F / +225 °F
NBR	-23 °C / +82 °C / -10 °F / +180 °F
Acetal	-40 °C / +120 °C / -40 °F / +250 °F
Hytre [®]	-29 °C / +104 °C / -20 °F / +220 °F
Neoprene	-18 °C / +93 °C / 0 °F - 200 °F
Santoprene [®]	-40 °C / +135 °C / -40 °F / +275 °F
Viton [®]	-40 °C / +177 °C / -40 °F / +350 °F
Polypropylene	0 °C / +65°C / +32 °F / +150 °F

SAFETY MEASURES



- Ensure that operators using this equipment are trained on the operation, the product and its limitations.
- Use safety equipment as required.
- Do not use a model with aluminium wetted parts to pump fluids for human consumption, there is a possibility of trace contamination of lead.
- Do not exceed the air maximum pressure: 100 psi (7 bar). Make sure that hoses and other components are rated for the pump maximum working pressure. Check all hoses for damage or wear.
- Never use a pump that leaks, that is damaged, that is corroded or otherwise it may lack the capacity to contain the fluid. Frequently check that the bolts on the pump fluid covers are correctly torqued.
- Check the diaphragm conditions. If a diaphragm is broken, the fluid can leak out of the air exhaust and cause personnel injuries or contaminate the environment.
- When handling hazardous fluids, always route the air exhaust into a suitable container and locate it in a safe place. Install a suitable container surrounding the pump to prevent any leaks or spills.

FIRE AND EXPLOSION HAZARD



- Prevent static sparking. If static sparking occurs, fire or explosion could result. Pump, valves, and containers must be properly grounded when handling flammable fluids and whenever discharge of static electricity is a hazard.
- Danger of explosion if 1,1,1-trichloroethane, methylene chloride or other halogenated hydrocarbon solvents are used with wetted parts made from aluminium. It could cause serious injury and property damage. Check the motor section of the pump, fluid covers, manifolds and all wetted parts in order to ensure compatibility before using these solvents.
- In order to avoid hazardous conditions that can cause fire or explosion all label and marking material must be cleaned to enable proper reading.

2024_02_01-10:00

DESCRIPTION

Air operated double diaphragm pumps are air-powered, reciprocating positive displacement pumps.

They have two opposite pump volumes and a diaphragm divides each volume into an air and a liquid chamber. The diaphragms are connected with a shaft. During one pumping stroke, the fluid is suctioned into one of the liquid chambers while simultaneously the other one is discharged.

INSTALLATION

RECOMMENDATIONS

- Install the pump as close as possible to the fluid being pumped to minimise the suction head.
 - For the ease of operation and service, mount the pump so there is enough space around it.
 - If the pump is installed in a place where fluid leakage can cause an environmental impact, the exhaust should be directed to a place where it can be contained.
 - When installing the pump in its place, use brackets to secure its base.
 - Fasten all bolts with the torques contained in this manual (REPAIR AND MAINTENANCE section). Let the pump running for a whole day. After that, check the torques again.
- UP pumps can be installed with flooded suction, suction lift or submerged in the fluid pumped. The figure below shows the recommended configuration for the pump installation.

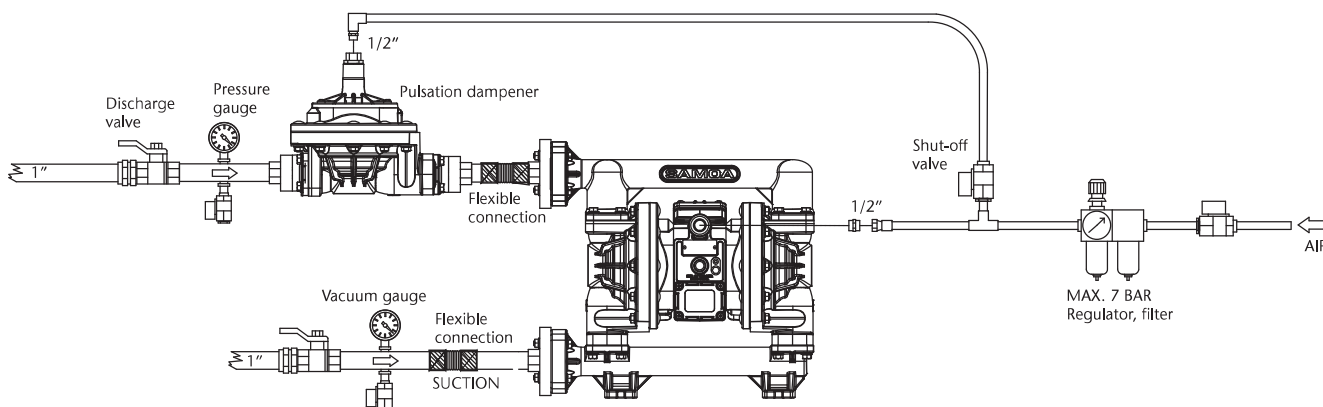

AIR EXHAUST DISPOSAL

WARNING: The pump exhaust should be directed to a safe place, away from people, animals and food.

- Remove the pump air muffler.
- Connect a hose with a 1" NPT thread to the new exhaust port and install the muffler at the end of the hose.
- Be sure the air exhaust is directed to a safe place.

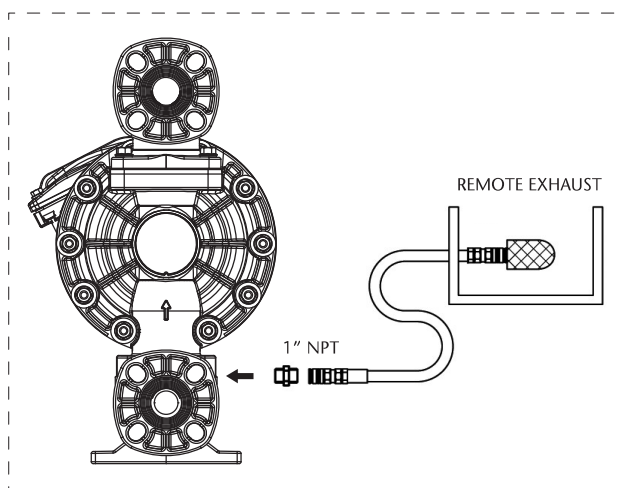

2024_02_01-10:00

AIR CONNECTION

WARNING

- To ensure that the air flow is sufficient to meet the pump demand, the air pipe diameter must be equal to the pump air inlet.

- Air treatment equipment must be dimensioned to meet pump air demand. It must be installed as close as possible to the pump unit.
- Using air quick couplers to connect the air hoses facilitates pump maintenance.

This pump is self-priming. To prime it for the first time connect the pump air inlet to a low air pressure supply. Keep the outlet valve open and gradually increase the pressure until the fluid comes out of the pump outlet. The air pressure supply must be between 1 and 7 bar (20 and 100 psi). For the performance characteristics of the pump see the performance chart (TECHNICAL DATA section).

STOPPING THE PUMP FOR MAINTENANCE TASKS

- Shut off the air supply to the pump.
- Check that the air valve is closed.
- Close the discharge valve and the suction valve. Open inlet and outlet drain valves if installed.
- Open the air valve of the pump, start up the pump and flush the remaining fluid.
- Close the air valve.
- Maintenance can be started after ensuring that the pump is turned off and the pressure is released.
- Unground the pump.

GROUNDING THE PUMP



WARNING: If the pump operates ungrounded or with an incorrect connection, friction between parts and fluid abrasion can generate static electricity. Depending on the fluid pumped and the installation environment, static electricity can cause either fire or electric shock.

When installing the pump, be sure to perform grounding in the specified location if required.

Also connect ground wires for the auxiliary equipment and piping. Use a grounding cable of at least 12 AWG (2.0 mm).

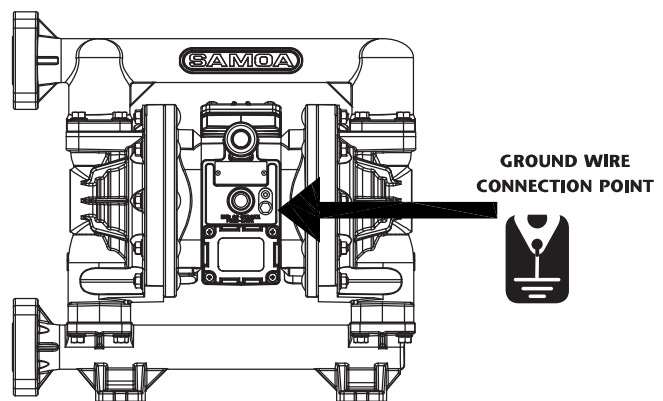

ATEX CERTIFIED PUMP

If your pump is ATEX certified, a specific Atex manual is included. Read this manual before operating the pump

If the symbol "Ex" is in the pump nameplate it can be used in the potentially explosive atmospheres indicated areas (details on the ATEX manual).



TROUBLESHOOTING

CAUSE	RECOMMENDED MEASURE
THE PUMP DOES NOT WORK	
Discharge valve on the discharge side is not open.	Open the valve on the discharge side.
No air supply.	Turn on the compressor and open the air valve and air regulator.
Low air supply pressure.	Check the compressor and the air line configuration.
Air leaks in connecting elements.	Check the connection elements and screws tightening.
Air pipes or additional equipment is clogged.	Check and clean the air line.
Pump exhaust port (muffler) is clogged.	Check and clean the exhaust port and muffler.
Fluid pipe is clogged.	Check and clean the fluid line.
Clogged pump.	Remove, inspect and clean the pump.

THE PUMP RUNS BUT NO FLUID COMES OUT	
Valve on the suction side is not open.	Open the valve on the suction side.
Too much suction or discharge height.	Reduce lengths/heights of suction and discharge pipes.
Fluid pipe on the discharge side (including the filter) is clogged.	Check and clean the fluid line.
Clogged pump.	Dismantle the pump, check and clean.
Balls and/or ball seats are worn or damaged.	Inspect and replace parts.

DECREASING FLOW	
Low air supply.	Check the compressor and the air line configuration.
Air line or peripheral equipment is clogged.	Check and clean the air line.
Valve on the discharge side will not open normally.	Adjust the discharge valve on the discharge side.
Air mixes with the fluid.	Replenish with fluid and check the pipe configuration on the suction side.
Pump is vibrating.	Adjust air supply pressure and discharge pressure. Reduce the inlet valve flow to adjust the pressure and fluid volume. Securely fix the pump with the bracket to the base.
Ice formation in the air exhaust.	Remove ice from the air bypass valve and check and clean the air filter. Use a pipe in the air exhaust so there is no ice formation in the muffler (see AIR EXHAUST DISPOSAL).
Fluid line (including the filter) is clogged.	Check and clean the fluid pipe and strainer.
Pump exhaust port (muffler) is clogged.	Check and clean the exhaust port and muffler.
Clogged pump.	Remove, inspect and clean the pump body.

THE FLUID COMES OUT WITH AIR BUBBLES	
Damaged diaphragm.	Replace diaphragm.
Loose or broken suction hose.	Tighten or replace.

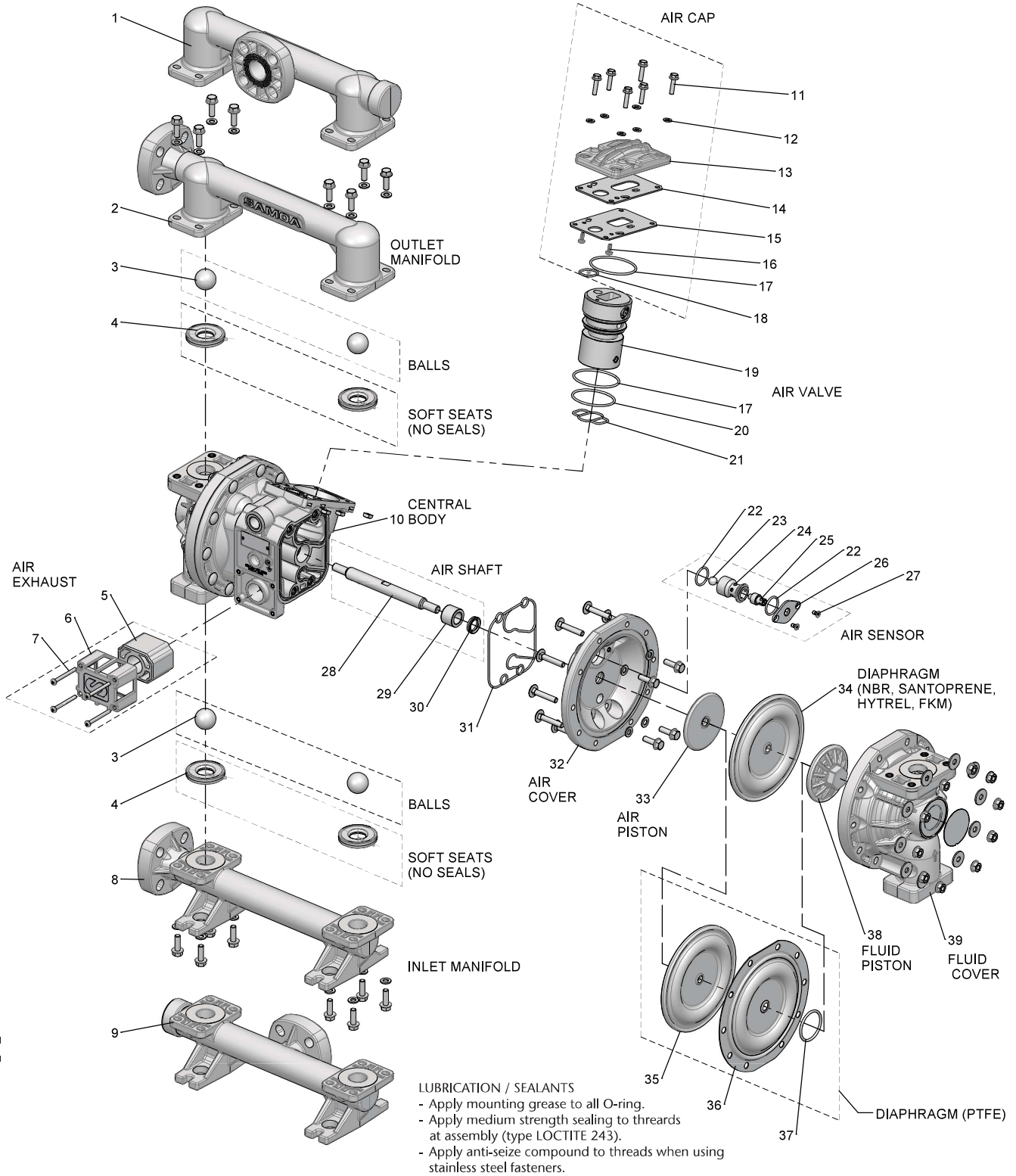

2024_02_01-10:00

TECHNICAL CHARACTERISTICS LABEL

CE Version

		II 2G Ex h IIB/IC T6...T5 Gb II 2D Ex h IIB T85°C...T110°C Db
www.samoaindustrial.com MADE IN SPAIN • PATENTED		
MODEL: UP10		
CODE: UP10X-XXX-XXX-X		
MFG. DATE: XXXX SERIAL No.: XXXXXXXXXX XXX		
MAX. AIR / FLUID PRESSURE: 7 bar / 100 psi		
FLUID IN / OUT: XXXX XXX		
CE UK CA EAC	OTEX	PATENTED

ATEX Version

		II 2G Ex h IIB/IC T6...T5 Gb II 2D Ex h IIB T85°C...T110°C Db
www.samoaindustrial.com MADE IN SPAIN • PATENTED		
MODEL: UP10		
CODE: UP10X-XXX-XXX-X		
MFG. DATE: XXXX SERIAL No.: XXXXXXXXXX XXX		
MAX. AIR / FLUID PRESSURE: 7 bar / 100 psi		
FLUID IN / OUT: XXXX XXX		
CE UK CA EAC	OTEX	PATENTED

MODEL: SXXXXX
 (numerical coding)
 UP10X-XXX-XXX
 (alphanumeric coding)

UP10 PLASTIC PUMP PARTS DRAWING

UP10	X	-	X	X	X	-	X	X	X
	1		3				4	5	6
CENTRAL BODY & AIR CHAMBERS	FLUID PORTS & LOCATION	FLUID CHAMBERS & MANIFOLDS	HARDWARE BOLTS	VALVE SEATS	VALVE BALLS	DIAPHRAGM			
B Conductive Polypropylene	Central ports: C 1" ANSI/DIN Flanged Ports B 1" BSP Threaded Ports N 1" NPT Threaded Ports Lateral ports: F 1" ANSI/DIN Flanged Ports P 1" BSP Threaded Ports T 1" NPT Threaded Ports	P Polypropylene W PVDF B Conductive Polypropylene	S Stainless steel	P Polypropylene T PTFE	H Hytrel® M Santoprene® N Nitrile (Buna-N) T PTFE (Teflon®) V FKM (Viton®)	A Santoprene® C Hytrel® G Nitrile (Buna-N) V FKM (Viton®) Two-piece: Z PTFE (Teflon® with Santoprene® backer)			

1	HOUSING PARTS REPAIR KITS										
	CENTRAL BODY			AIR COVER		AIR CAP				AIR PISTON	
	Kit Code	Incl. Pos.	Kit Code	Incl. Pos.	Kit Code	Incl. Pos.			Kit Code	Incl. Pos.	
B	UP10R-HP-5B0	10	UP10R-HP-4B0	32	UP10R-HP-8B0	6x(11), 6x(12), 13, 14, 15, 2x(16), 17, 18			UP10R-HP-6S0	2x(33)	

1	AIR MOTOR REPAIR KITS									
	AIR EXHAUST		AIR SHAFT		SEALS		AIR VALVE		AIR SENSOR	
	Kit Code	Incl. Pos.	Kit Code	Incl. Pos.	Kit Code	Incl. Pos.	Kit Code	Incl. Pos.	Kit Code	Incl. Pos.
B	UP10R-AM-500	5, 6, 4X(7)	UP10R-AM-300	28, 2x(29), 2x(30)	UP10R-WP-400	14, 2x(17), 18, 20, 21, 2x(30), 2x(31)	UP10R-AM-1A0	2x(17), 19, 20, 21	UP10R-AM-201	4x(22), 2x(23), 2x(24), 2x(25), 2x(26), 4x(27)

3	HOUSING PARTS REPAIR KITS			
	FLUID PISTON		FLUID COVER	
	Kit Code	Incl. Pos.	Kit Code	Incl. Pos.
P	UP10R-HP-7P0		UP10R-HP-3P0	
B	UP10R-HP-7B0	2x(38)	UP10R-HP-3B0	39
W	UP10R-HP-7W0		UP10R-HP-3W0	

4	WETTED PARTS REPAIR KITS		
	SEATS		
	PTFE Seals	Kit Code	Incl. Pos.
P	T*	UP10R-WP-A00	
N	T*	UP10R-WP-N00	4x(4)

* Available as kit UP10R-WP-999 (contains 8 PTFE O-rings).

3	HOUSING PARTS REPAIR KITS							
	INLET MANIFOLD (CENTRAL PORT)				INLET MANIFOLD (LATERAL PORT)			
	Kit Code (Flange)	Kit Code (BSP)	Kit Code (NPT)	Incl. Pos.	Kit Code (Flange)	Kit Code (BSP)	Kit Code (NPT)	Incl. Pos.
P	UP10R-HP-1PC	UP10R-HP-1PB	UP10R-HP-1PN	9	UP10R-HP-1PF	UP10R-HP-1PP	UP10R-HP-1PNT	8
B	UP10R-HP-1BC	UP10R-HP-1BB	UP10R-HP-1BN		UP10R-HP-1BF	UP10R-HP-1BP	UP10R-HP-1BT	
W	UP10R-HP-1WC	UP10R-HP-1WB	UP10R-HP-1WN		UP10R-HP-1WF	UP10R-HP-1WP	UP10R-HP-1WT	
	OUTLET MANIFOLD (CENTRAL PORT)				OUTLET MANIFOLD (LATERAL PORT)			
	Kit Code (Flange)	Kit Code (BSP)	Kit Code (NPT)	Incl. Pos.	Kit Code (Flange)	Kit Code (BSP)	Kit Code (NPT)	Incl. Pos.
P	UP10R-HP-2PC	UP10R-HP-2PB	UP10R-HP-2PN	1	UP10R-HP-2PF	UP10R-HP-2PP	UP10R-HP-2PT	2
B	UP10R-HP-2BC	UP10R-HP-2BB	UP10R-HP-2BN		UP10R-HP-2BF	UP10R-HP-2BP	UP10R-HP-2BT	
W	UP10R-HP-2WC	UP10R-HP-2WB	UP10R-HP-2WN		UP10R-HP-2WF	UP10R-HP-2WP	UP10R-HP-2WT	

5	WETTED PARTS REPAIR KITS	
	BALLS	
	Kit Code	Incl. Pos.
H	UP10R-WP-0H0	4x(3)
M	UP10R-WP-0M0	
N	UP10R-WP-0N0	
T	UP10R-WP-0S0	
V	UP10R-WP-0V0	

6	WETTED PARTS REPAIR KITS	
	TWO PIECE DIAPHRAGMS	
	Kit Code	Incl. Pos.
C	UP10R-WP-00A	2x(34)
A	UP10R-WP-00C	
G	UP10R-WP-00G	
V	UP10R-WP-00V	
Z	UP10R-WP-00Z	

2024_02_01-10:00

TORQUE SPECIFICATIONS

For proper pump operation and to prevent accidents, you must periodically review the torques of the diaphragms covers and the directional valve. The table shows the appropriate torques for this purpose:

⚠ CAUTION!: DO NOT OVERTIGHTEN FASTENERS.
SHUT OFF THE AIR SUPPLY BEFORE ANY INTERVENTION.
BE AWARE OF A POSSIBLE FLUID LEAKAGE INSIDE THE PUMP.

	UP10B-XXX-XXX
Fluid chamber	12 N·m (8,85 ft·lbs)
Manifolds	7 N·m (5,16 ft·lbs)
Fluid piston	15 N·m (11,06 ft·lbs)
Air cover	12 N·m (8,85 ft·lbs)
Air cap	6 N·m (4,42 ft·lbs)

AIR VALVE

1. Unscrew the air cap and remove it.
2. Pull out the air valve.
3. Place the bottom gasket in the new air valve.
4. Insert the new air valve.
5. Place the "air cap" with the gaskets in its housing.
6. Tighten the screws with 15 N·m (11 ft.lbs) torque.

AIR SENSOR

The air sensors are on the central body.
First follow the procedure for "Replacing diaphragms".

Once the fluid covers are removed proceed as follows:

1. Remove the two screws that secure the air sensor to the top.
2. Remove all sensor components. Clean the area.
3. Insert new components in the order shown. Assemble the remaining components in reverse order.
4. Fit the sensor cover and tighten the screws.

CAUTION! TIGHTENING SEQUENCE

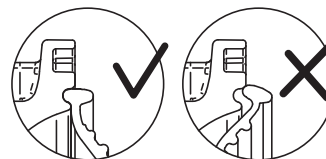
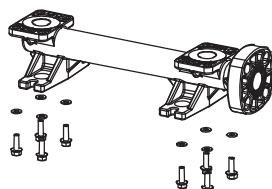
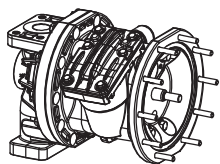
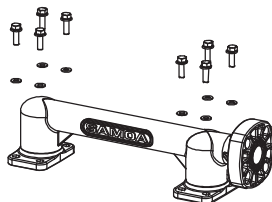
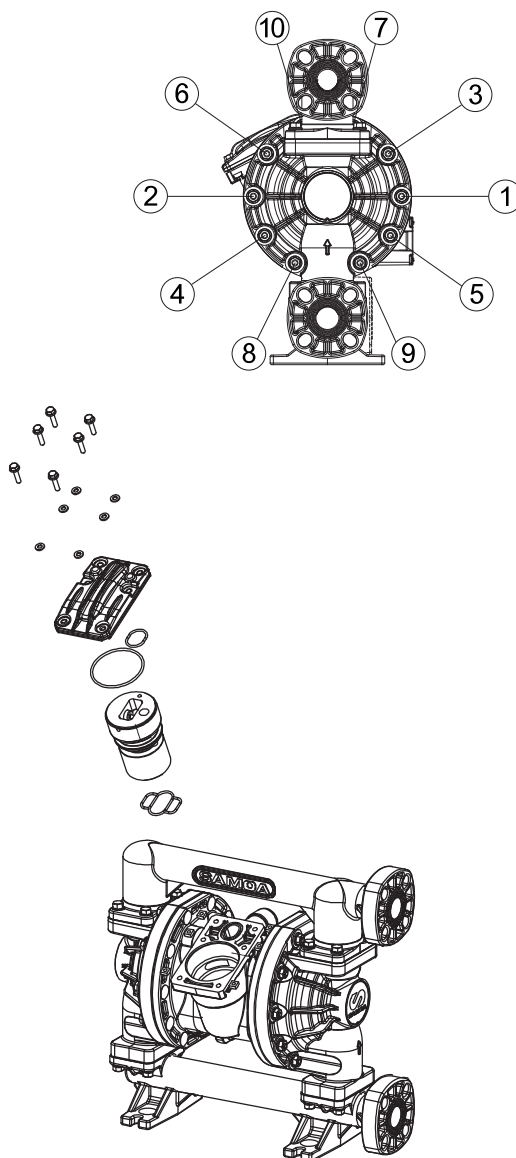

IMPORTANT:

Follow the diaphragm maintenance procedure to ensure no damage in the diaphragm during its assembly.

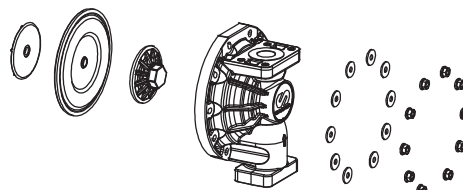

REPAIR AND MAINTENANCE

SHAFT, BUSHINGS AND SEALS

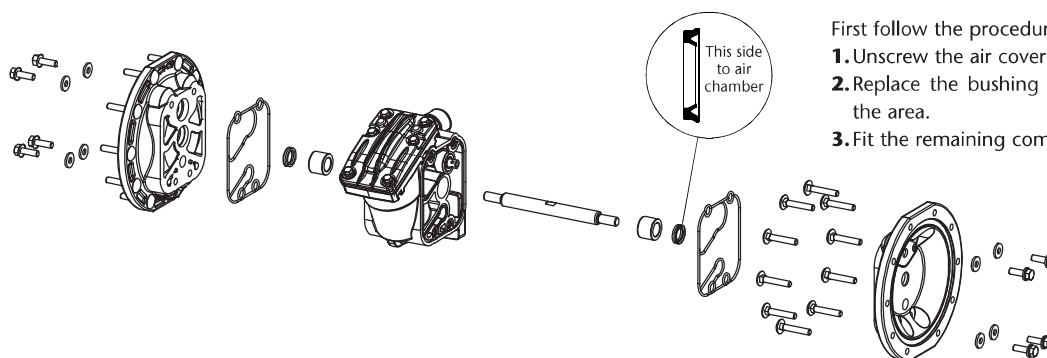

First follow the procedure for "Replacing diaphragms".

1. Unscrew the air cover and lift it.
2. Replace the bushing and seals. Clean and lubricate the area.
3. Fit the remaining components in reverse order.

BALLS AND SEATS

Before opening the pump follow the steps in STOPPING THE PUMP FOR MAINTENANCE TASKS (page 6).

1. Remove the inlet and outlet manifolds.
 2. Install a new set of balls or seats or according to these assembly drawings. Tighten the manifold bolts with 25 N·m (18 ft.lbs) torque.
- IMPORTANT:** Gradually tighten the manifold with the bolts before proceeding with the final tightening.

IMPORTANT:

Soft seats (NBR, Hytrel® and Santoprene®) don't need extra seals and the seats can be assembled upside down.

Hard seats (PP, POM, PVDF, aluminum, stainless steel), use additional o-rings for sealing.

Balls must be always assembled over the seat.

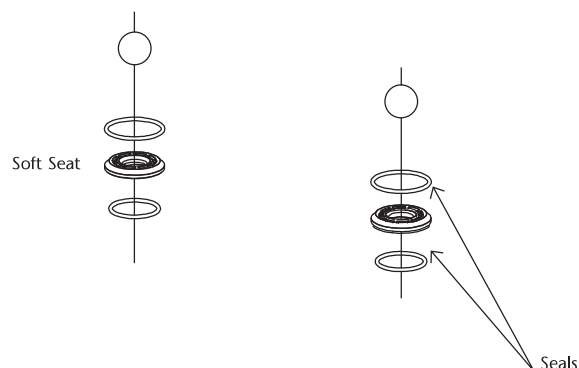

IMPORTANT: If the pump maintenance involves disassembling the manifolds and the pump is configured with PTFE o-rings (white colour), they must be replaced by new ones in order to avoid fluid leakages.

DIAPHRAGM

Before opening the pump follow the steps in STOPPING THE PUMP FOR MAINTENANCE TASKS (page 6).

1. Unscrew the outlet manifold and lift it. Remove the valve seats, o-ring (if applicable) and balls.
2. Turn the pump upside down to remove the inlet manifold screws. Remove the seats, seals (if necessary) and balls.
3. Unscrew the fluid cover screws and remove it by gently pulling back.
4. Remove the used diaphragm. For one-piece diaphragms unscrew by pulling with the hand. In case of two-piece diaphragms (diaphragm with outer piston) use an adjustable wrench and apply corresponding torque.
5. Repeat for opposite side.

NOTE:

Use a torque wrench to tighten the screws (see torques table).

INSTALLING NEW DIAPHRAGMS

- CAUTION:** Follow next procedure to ensure the diaphragms are correctly installed. Otherwise diaphragms may be damaged, causing fluid leaks or premature diaphragm failure. Please note this recommendation if you notice leaks after installing the diaphragm.

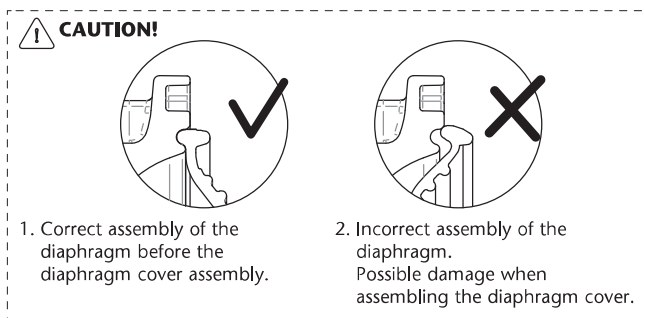

1. Correct assembly of the diaphragm before the diaphragm cover assembly.

2. Incorrect assembly of the diaphragm. Possible damage when assembling the diaphragm cover.

2024_02_01-10:00

EC CONFORMITY DECLARATION / DECLARATION CE DE CONFORMIDAD / DÉCLARATION CE DE CONFORMITÉ / EG-KONFORMITÄTSERLÄRUNG

EN

SAMOA INDUSTRIAL, S.A., Pol. Ind. Porceyo, I-14 · Camino del Fontán, 831 · 33392 - Gijón - Spain, declares that the product(s):

UP10X-XXX-XXX

conform(s) with the EU Directive(s):

2006/42/EC

ES

SAMOA INDUSTRIAL, S.A., Pol. Ind. Porceyo, I-14 · Camino del Fontán, 831 · 33392 - Gijón - España, declara que el(los) producto(s):

UP10X-XXX-XXX

cumple(n) con la(s) Directiva(s) de la Unión Europea:

2006/42/CE

FR

SAMOA INDUSTRIAL, S.A., Pol. Ind. Porceyo, I-14 · Camino del Fontán, 831 · 33392 - Gijón - Espagne, déclare que le(s) produit(s):

UP10X-XXX-XXX

est conforme à la (aux) directive(s) de l'UE:

2006/42/EG

DE

SAMOA INDUSTRIAL, S.A., Pol. Ind. Porceyo, I-14 · Camino del Fontán, 831 · 33392 - Gijón - Spanien, bestätigt hiermit, dass dieses Produkt:

UP10X-XXX-XXX

der EG-Richtlinie(n):

2006/42/EG

For SAMOA INDUSTRIAL, S.A.
Por SAMOA INDUSTRIAL, S.A.
Pour SAMOA INDUSTRIAL, S.A.
Für SAMOA INDUSTRIAL, S.A.

Pedro E. Prallong Álvarez
Production Director
Director de Producción
Directeur de Production
Produktionsleiter

2024_02_01-10:00

RU

EAC

Сертификат соответствия:

ЕАЭК № RU Д-ЕС.АБ58.В.02842/20, срок действия с 12.08.2020 по 11.08.2025, выдан органом по сертификации продукции «М-ФОНД» ООО «Агентство по экспертизе и испытаниям продукции»; Адрес 125167, Россия, г. Москва, ул. Викторенко, дом 16, стр. 1. Телефон: +74951501658, e-mail: info@mfond.org. Аттестат аккредитации №РА. RU.11АБ58 от 07.04.2016 года.

Дата производства указана на маркировке изделия

Транспортировка

Изделие должно транспортироваться в заводской упаковке для защиты от повреждений и влаги.

Хранение

Изделие должно храниться запечатанным, в хорошо проветриваемом и сухом помещении.

Утилизация

Выполняйте национальные правила утилизации и переработки отслужившего оборудования, упаковки и принадлежностей.